

Rotary Cutters

RCF2784

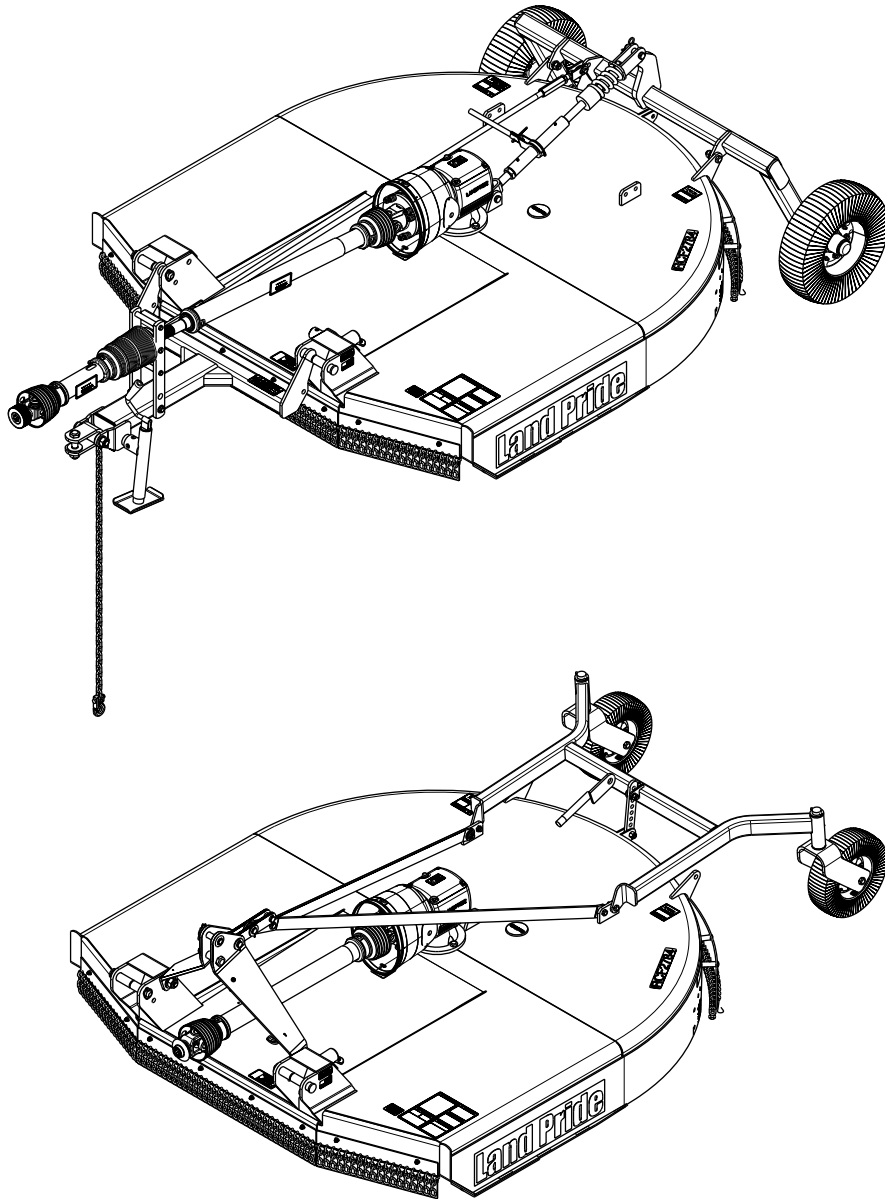

30697

326-364M
Operator's Manual



Read the Operator's Manual entirely. When you see this symbol, the subsequent instructions and warnings are serious - follow without exception. Your life and the lives of others depend on it!

Cover illustration may show optional equipment not supplied with standard unit.

© Copyright 2015 Printed 12/15/15



Important Safety Information	1	Section 2: Adjustments	20
Safety at All Times	1	3-Point Leveling & Cutting Height	20
Look For The Safety Alert Symbol	1	Deck Leveling	20
Safety Labels	4	Cutting Height Adjustment	20
Introduction	7	Single & Dual Tailwheel Adjustment	21
Application	7	Center 3-Point Link Adjustment	21
Using This Manual	7	Pull-Type Deck Leveling & Cutting Height	22
Terminology:	7	Deck Leveling	22
Definitions:	7	Front To Back Deck Leveling	22
Owner Assistance	7	Cutting Height Adjustment	23
Serial Number	7	Section 3: Operating Instructions	24
Further Assistance	7	Operating Checklist	24
Section 1: Assembly & Set-up	8	Safety Information	24
Tractor Requirements	8	Inspection of Tractor & Cutter	25
Torque Requirements	8	Transporting	26
Uncrating Instructions	8	Blade Engagement & Disengagement	26
Gearbox Vented Dipstick	8	Blade Engagement	26
3-Point Cutter Assembly & Set-up	9	Blade Disengagement	26
3-Point Hitch	9	Field Operation	26
3-Point Single Tailwheel Option	10	Unhooking the Rotary Cutter	27
3-Point Dual Tailwheel Option	11	General Operating Instructions	27
3-Point Tractor Hook-up	12	Section 4: Maintenance & Lubrication	29
Driveline Installation	12	Maintenance	29
Check Driveline Collapsible Length	13	Slip-Clutch Protected Drivelines	29
Shorten Driveline	13	Clutch Run-In	29
Check Driveline Maximum Length	14	Clutch Assembly and Disassembly	30
Check Driveline Interference	14	Disassembly	30
Pull-Type Cutter Assembly & Set-up	14	Cutter Blade Maintenance	30
Hitch Assembly	14	Skid Shoe Maintenance	32
Driveline Installation	15	Long Term Storage	33
Axle Assembly	16	Ordering Replacement Parts	33
Pull-Type Tractor Hook-up	17	Lubrication Points	34
Hydraulic Hook-up	18	Gauge Wheel Spindle Tube (3-Point Cutters)	34
Purge Hydraulic System	18	Gauge Wheel Hub	34
Assembly of Optional Guards	18	Gearbox	34
Front Rubber Guard	18	Driveline U-Joints	35
Front Single or Double Chain Guard	18	Driveline Shield Bearings	35
Rear Single or Double Chain Guards	19	Driveline Profiles	35
		Ratchet Jack (Optional)	35
		Section 5: Specifications & Capacities	36
		Section 6: Features & Benefits	38
		Section 7: Troubleshooting	39
		Section 8: Torque Values Chart	40
		Section 9: Warranty	41



© Copyright 2015 All rights Reserved

Land Pride provides this publication "as is" without warranty of any kind, either expressed or implied. While every precaution has been taken in the preparation of this manual, Land Pride assumes no responsibility for errors or omissions. Neither is any liability assumed for damages resulting from the use of the information contained herein. Land Pride reserves the right to revise and improve its products as it sees fit. This publication describes the state of this product at the time of its publication, and may not reflect the product in the future.

Land Pride is a registered trademark.

All other brands and product names are trademarks or registered trademarks of their respective holders.

Printed in the United States of America.

Important Safety Information

These are common practices that may or may not be applicable to the products described in this manual.

Safety at All Times

Thoroughly read and understand the instructions given in this manual before operation. Refer to the "Safety Label" section, read all instructions noted on them.

Do not allow anyone to operate this equipment who has not fully read and comprehended this manual and who has not been properly trained in the safe operation of the equipment.

- ▲ The operator must not use drugs or alcohol as they can change the alertness or coordination of that person while operating equipment. The operator should, if taking over-the-counter drugs, seek medical advice on whether he/she can safely operate the equipment.
- ▲ Operator should be familiar with all functions of the tractor and attachments, and be able to handle emergencies quickly.
- ▲ Make sure all guards and shields are in place and secured before operating implement.
- ▲ Keep all bystanders away from equipment and work area.
- ▲ Operator must start tractor and operate controls from the driver's seat only. Never from the ground.
- ▲ Do not leave tractor or implement unattended with engine running.
- ▲ Dismounting from a moving tractor can cause serious injury or death.
- ▲ Do not allow anyone to stand between tractor and implement while backing up to implement.
- ▲ Keep hands, feet, and clothing away from power-driven parts.
- ▲ Watch out for fences, trees, rocks, wires, etc., while operating and transporting implement.
- ▲ Turning tractor too tight may cause hitched machinery to ride up on wheels. This could result in injury or equipment damage.

Look For The Safety Alert Symbol



The SAFETY ALERT SYMBOL indicates there is a potential hazard to personal safety involved and extra safety precaution must be taken. When you see this symbol, be alert and carefully read the message that follows it. In addition to design and configuration of equipment, hazard control, and accident prevention are dependent upon the awareness, concern, prudence, and proper training of personnel involved in the operation, transport, maintenance, and storage of equipment.

Be Aware of Signal Words

A Signal word designates a degree or level of hazard seriousness. The signal words are:

⚠ DANGER

Indicates an imminently hazardous situation which, if not avoided, will result in death or serious injury. This signal word is limited to the most extreme situations, typically for machine components that, for functional purposes, cannot be guarded.

⚠ WARNING

Indicates a potentially hazardous situation which, if not avoided, could result in death or serious injury, and includes hazards that are exposed when guards are removed. It may also be used to alert against unsafe practices.

⚠ CAUTION

Indicates a potentially hazardous situation which, if not avoided, may result in minor or moderate injury. It may also be used to alert against unsafe practices.

For Your Protection

- ▲ Thoroughly read and understand the "Safety Label" section, read all instructions noted on them.

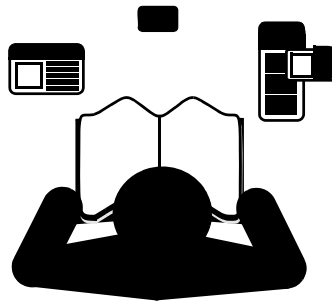

Tractor Shutdown & Storage

- ▲ If engaged, disengage PTO.
- ▲ Lower attached implement to ground, put tractor in park or set park brake, turn off engine, and remove switch key to prevent unauthorized starting.
- ▲ Wait for all components to come to a complete stop before leaving the operator's seat.
- ▲ Detach and store implement in an area where children normally do not play. Secure implement using blocks and supports.

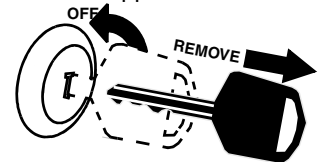

Parts Manual QR Locator

The QR (Quick Reference) code on the front cover and to the left will take you to the Parts Manual for this equipment. Download the appropriate App on your smart phone, open the App, point your phone on the QR code and take a picture.



Dealer QR Locator

The QR code on the left will link you to available dealers for Land Pride products. Refer to Parts Manual QR Locator on this page for detailed instructions.

Important Safety Information

These are common practices that may or may not be applicable to the products described in this manual.

Use Safety Lights and Devices

- ▲ Slow moving tractors, self-propelled equipment, and towed implements can create a hazard when driven on public roads. They are difficult to see, especially at night.
- ▲ Flashing warning lights and turn signals are recommended whenever driving on public roads.

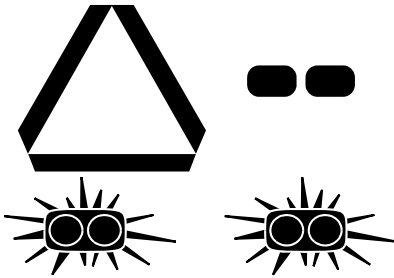

Transport Machinery Safely

- ▲ Comply with state and local laws.
- ▲ Use towing vehicle and trailer of adequate size and capacity.
- ▲ Secure equipment towed on a trailer with tie downs and chains.
- ▲ Sudden braking can cause a trailer to swerve and upset. Reduce speed if trailer is not equipped with brakes.
- ▲ Avoid contact with any over head utility lines or electrically charged conductors.
- ▲ Engage park brake when stopped on an incline.

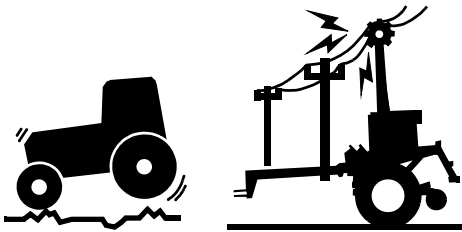

- ▲ Maximum transport speed for an attached implement is 20 mph. DO NOT EXCEED. Never travel at a speed which does not allow adequate control of steering and stopping. Some rough terrains require a slower speed.
- ▲ As a guideline, use the following maximum speed weight ratios for an attached implement:
 - 20 mph** when weight of attached implement is less than or equal to the weight of machine towing the implement.
 - 10 mph** when weight of attached implement exceeds weight of machine towing implement but not more than double the weight.
- ▲ **IMPORTANT:** Do not tow a load that is more than double the weight of the machine towing the load.

Use A Safety Chain

- ▲ A safety chain will help control drawn machinery should it separate from the tractor drawbar.
- ▲ Use a chain with the strength rating equal to or greater than the gross weight of the towed machinery.
- ▲ Attach the chain to the tractor drawbar support or other specified anchor location. Allow only enough slack in the chain to permit turning.
- ▲ Do not use safety chain for towing.

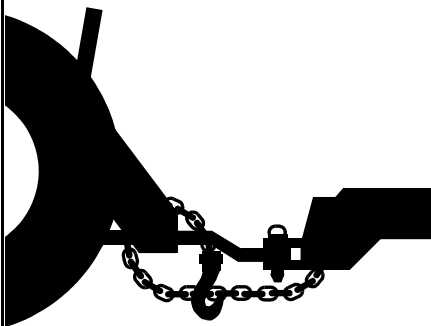

Practice Safe Maintenance

- ▲ Understand procedure before doing work. Use proper tools and equipment, refer to Operator's Manual for additional information.
- ▲ Work in a clean dry area.
- ▲ Lower attached implement to the ground, put tractor in park, turn off engine, and remove key before performing maintenance.
- ▲ Allow implement to cool before working on it.
- ▲ Disconnect battery ground cable (-) before servicing or adjusting electrical systems or before welding on implement.

- ▲ Do not grease or oil implement while it is in operation.
- ▲ Inspect all parts. Make certain parts are in good condition & installed properly.
- ▲ Replace parts on this machine with genuine Land Pride parts only. Do not alter this machine in a way which will adversely affect its performance.
- ▲ Remove buildup of grease, oil, or debris.
- ▲ Remove all tools and unused parts from implement before operation.



Important Safety Information

These are common practices that may or may not be applicable to the products described in this manual.

Prepare for Emergencies

- ▲ Be prepared if a fire starts.
- ▲ Keep a first aid kit and fire extinguisher handy.
- ▲ Keep emergency numbers for doctor, ambulance, hospital, and fire department near phone.

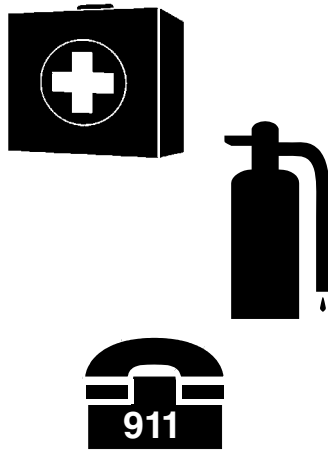

Wear Protective Equipment

- ▲ Wear protective clothing and equipment appropriate for the job such as safety shoes, safety glasses, hard hat, and ear plugs.
- ▲ Clothing should fit snug without fringes and pull strings to avoid entanglement with moving parts.
- ▲ Prolonged exposure to loud noise can cause hearing impairment or hearing loss. Wear suitable hearing protection such as earmuffs or earplugs.
- ▲ Operating equipment safely requires the operator's full attention. Avoid wearing radio headphones while operating machinery.



Avoid High Pressure Fluids Hazard

- ▲ Escaping fluid under pressure can penetrate the skin causing serious injury.
- ▲ Avoid the hazard by relieving pressure before disconnecting hydraulic lines or performing work on the system.
- ▲ Make sure all hydraulic fluid connections are tight and all hydraulic hoses and lines are in good condition before applying pressure to the system.
- ▲ Use a piece of paper or cardboard, NOT BODY PARTS, to check for suspected leaks.
- ▲ Wear protective gloves and safety glasses or goggles when working with hydraulic systems.
- ▲ **DO NOT DELAY.** If an accident occurs, see a doctor immediately. Any fluid injected into the skin must be treated within a few hours or gangrene may result.



Tire Safety

- ▲ Tire changing can be dangerous and should be performed by trained personnel using the correct tools and equipment.
- ▲ When inflating tires, use a clip-on chuck and extension hose long enough to allow you to stand to one side and NOT in front of or over the tire assembly. Use a safety cage if available.
- ▲ When removing and installing wheels, use wheel handling equipment adequate for the weight involved.



Use Seat Belt and ROPS

- ▲ Operate only tractors equipped with a Roll-Over Protective Structure (ROPS) and seat belt.
- ▲ Keep folding ROPS in the "locked up" position at all times.
- ▲ Fasten seat belt snugly and securely to help protect against serious injury or death from falling and machine overturn.
- ▲ Wear protective equipment such as a hard hat, safety shoes, safety glasses, and ear plugs.

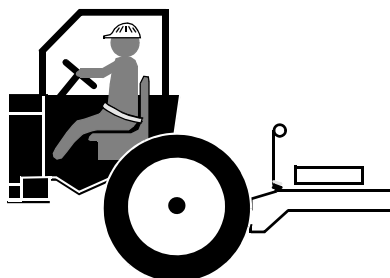

Keep Riders Off Machinery

- ▲ Never carry riders or use machinery as a person lift.
- ▲ Riders obstruct operator's view.
- ▲ Riders could be struck by foreign objects or thrown from the machine.
- ▲ Never allow children to operate equipment.

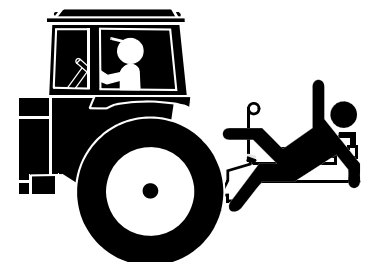

Important Safety Information

Safety Labels

Your Rotary Cutter comes equipped with all safety labels in place. They were designed to help you safely operate your implement. Read and follow their directions.

1. Keep all safety labels clean and legible.
2. Refer to this section for proper label placement. Replace all damaged or missing labels. Order new labels from your nearest Land Pride dealer. To find your nearest dealer, visit our dealer locator at www.landpride.com.
3. Some new equipment installed during repair requires safety labels to be affixed to the replaced component as

specified by Land Pride. When ordering new components make sure the correct safety labels are included in the request.

4. Refer to this section for proper label placement. To install new labels:
 - a. Clean surface area where label is to be placed.
 - b. Spray soapy water onto the cleaned area.
 - c. Peel backing from label and press label firmly onto the surface.
 - d. Squeeze out air bubbles with edge of a credit card or with a similar type of straight edge.

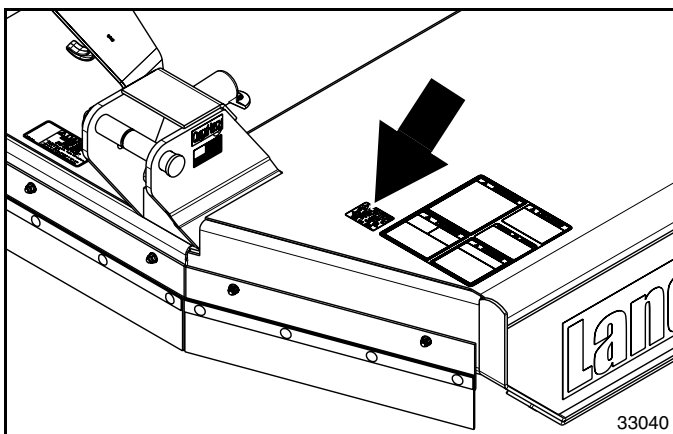

818-130C
Caution: 540 RPM

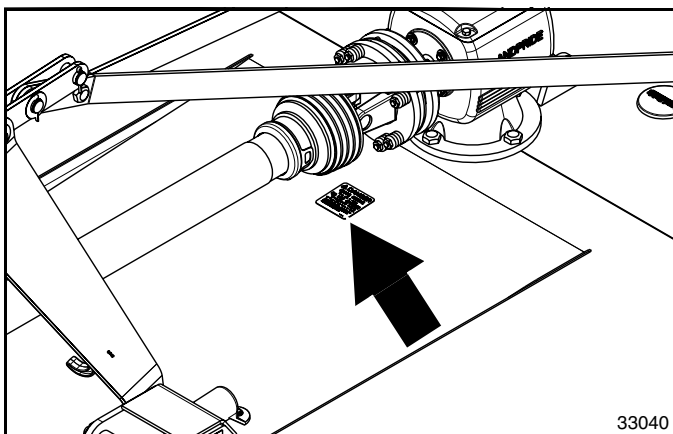

818-543C
Danger: Guard Missing

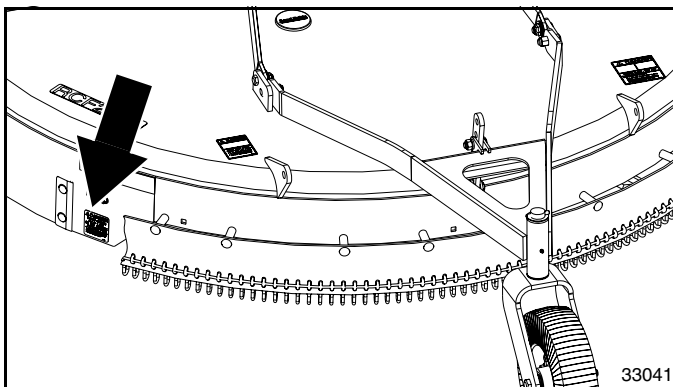

Important Safety Information

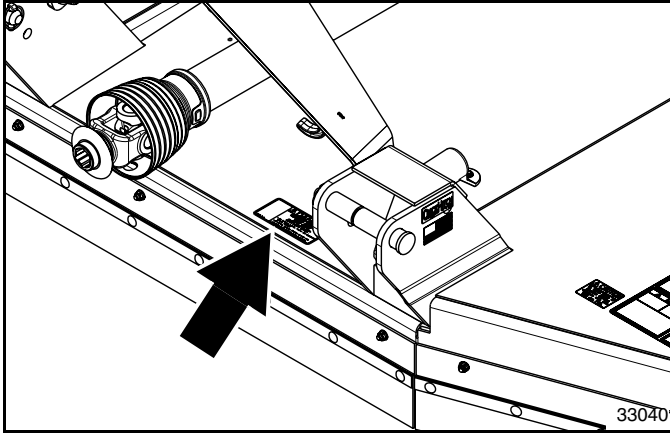

818-142C

Danger: Rotating Driveline

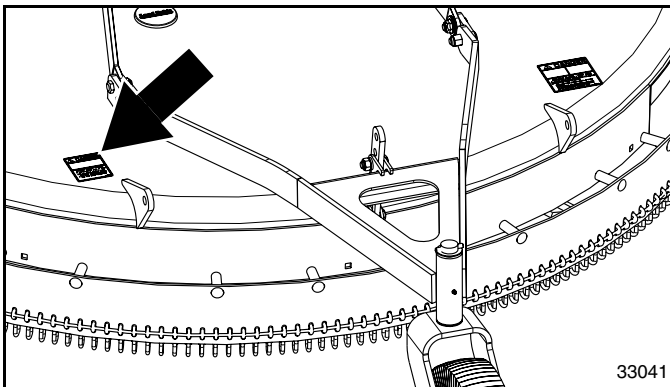

818-556C

Danger: Thrown Object

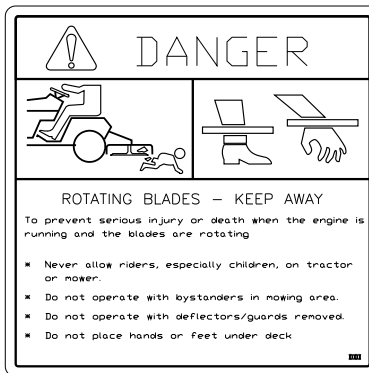
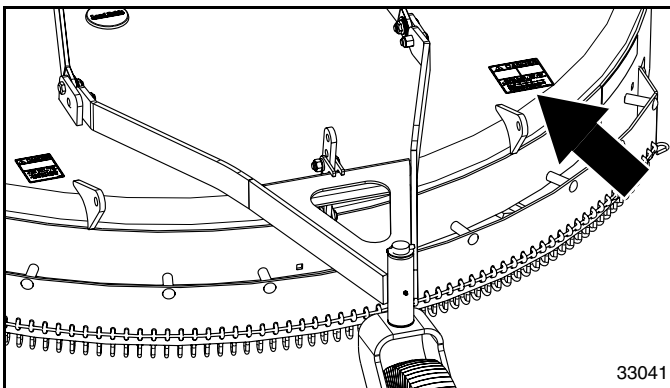

818-564C

Danger: Rotating Blades

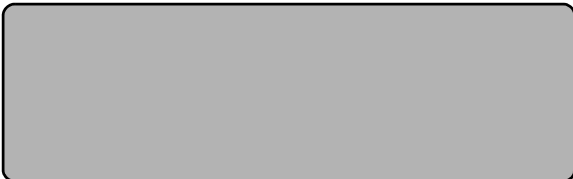
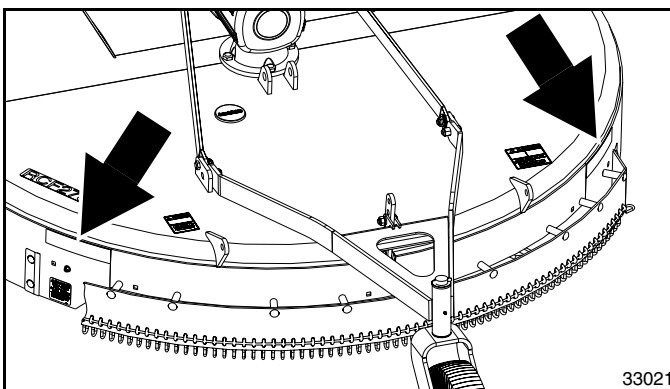

838-614C

Red Reflector (2 places)

Important Safety Information

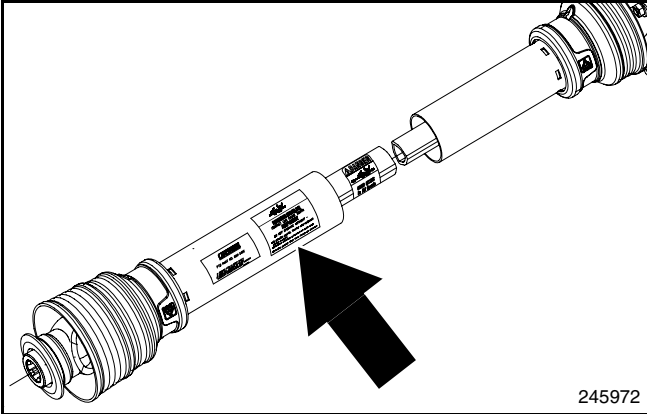

⚠ DANGER

ROTATING DRIVELINE CONTACT CAN CAUSE DEATH
KEEP AWAY!
DO NOT OPERATE WITHOUT –

- All driveline guards, tractor and equipment shields in place
- Drivelines securely attached at both ends.
- Driveline guards that turn freely on Driveline

818-552C

818-552C

Danger: Rotating Driveline

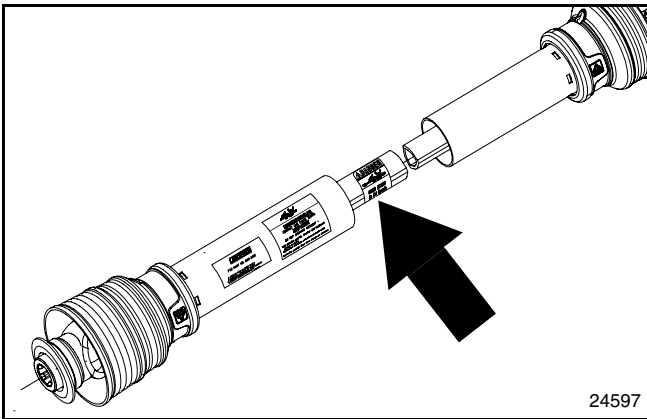

⚠ DANGER

GUARD MISSING
DO NOT OPERATE

⚠ DANGER

GUARD MISSING
DO NOT OPERATE

⚠ DANGER

818-540C

Danger: Guard Missing

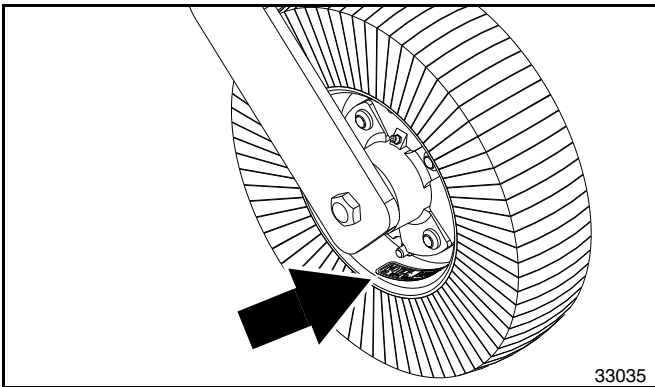

NOTICE:
20 MPH Max.

To Prevent Tire and/or Machine damage, Do Not Exceed 20 mph maximum transport speed.

818-681C

818-681C

Notice: 20 MPH Max.

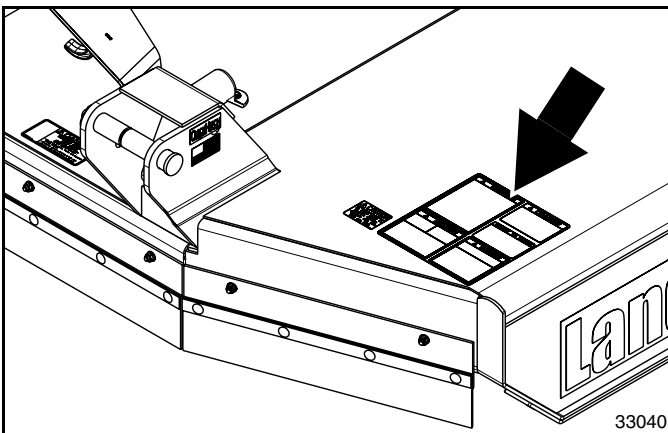

<p>⚠ WARNING</p> <p>To prevent serious injury or death:</p> <ul style="list-style-type: none"> • Read and understand Operator's Manual before using. Never modify. • Do not permit riders on the tractor or mower. Never carry children on tractor seat. • Do not allow children to operate mower. • Operate only with guards installed and in good condition. • Keep away from moving parts. • Operate only with tractor equipped with ROPS and seatbelts. • Before mowing, clear debris from mowing area. • Do not operate in the raised position. • Stop engine, set brake and wait for all moving parts to stop before dismounting. • Support mower securely before working beneath parts. • Transport with clean reflectors, SPV and warning lights as required by federal, state, and local laws. <p>If no tow hitch, use spade to align over all 4 tow bars and to distribute the load as required.</p>	<p>⚠ DANGER</p> <p>KEEP HANDS AND FEET AWAY</p>
<p>⚠ DANGER</p> <p>ROTATING BLADES – KEEP AWAY</p> <p>To prevent serious injury or death when the engine is running and the blades are rotating:</p> <ul style="list-style-type: none"> • Never allow riders, especially children, on tractor or mower. • Do not operate with bystanders in mowing area. • Do not operate with deflectors/guards removed. • Do not place hands or feet under deck. 	<p>NOTICE TO OWNER</p> <p>An OPERATOR'S MANUAL was attached to this implement during final inspection of the factory. If it was not attached at the time of purchase, please contact your selling dealer or store.</p> <ol style="list-style-type: none"> 1. Read and understand Manual BEFORE operating the implement. 2. Pay attention to the safety messages.
<p>⚠ DANGER</p> <p>THROWN OBJECT HAZARD</p> <p>To prevent serious injury or death:</p> <ul style="list-style-type: none"> • Do not operate unless all guards are installed and in good condition. • Stop blade rotation if bystanders come within several hundred feet. 	<p>818-830C</p> <p>Safety Combo</p>

Introduction

Land Pride welcomes you to the growing family of new product owners.

This Rotary Cutter has been designed with care and built by skilled workers using quality materials. Proper assembly, maintenance, and safe operating practices will help you get years of satisfactory use from this machine.

Application

The Heavy Duty RCF2784 Rotary Cutter is built and designed by Land Pride for cutting on gentle sloping or slightly contoured right-of-ways, pastures, set aside acres, and row crop fields. Its 84" cutting width and Quick Hitch capability makes it compatible with the 60 to 130 HP tractors with 540 rpm PTO speed, and Category II or III 3-Point or pull-type hitch. Its Category 4 driveline is protected with a 4 plate slip clutch.

The cutter removes grass, weeds, and light brush up to 3" in diameter and has a cutting height range of 1 1/2" to 12" with a cutting blade tip speed of 14,369 fpm. This unit comes with a standard 3/16" x 24" x 38" heavy-duty oval stump jumper and replaceable skid shoes. Optional front rubber deflector or front chain guard and rear chain guards are available.

See “**Specifications & Capacities**” on page 36 and “**Features & Benefits**” on page 38 for additional information and performance enhancing options.

Using This Manual

- This Operator’s Manual is designed to help familiarize the operator with safety, assembly, operation, adjustments, troubleshooting, and maintenance. Read this manual and follow the recommendations to help ensure safe and efficient operation.
- The information contained within this manual was current at the time of printing. Some parts may change slightly to assure you of the best performance.
- To order a new Operator’s or Parts Manual, contact your authorized dealer. Manuals can also be downloaded, free-of-charge, from our website at www.landpride.com

Terminology:

“Right” or “Left” as used in this manual is determined by facing the direction the machine will operate while in use unless otherwise stated.

Definitions:

IMPORTANT: A special point of information related to the following topic. Land Pride’s intention is this information must be read & noted before continuing.

NOTE: A special point of information that the operator should be aware of before continuing.

Owner Assistance

The Online Warranty Registration should be completed by the dealer at the time of purchase. This information is necessary to provide you with quality customer service.

The parts on your Rotary Cutter have been specially designed by Land Pride and should only be replaced with genuine Land Pride parts. Contact a Land Pride dealer if customer service or repair parts are required. Your Land Pride dealer has trained personnel, repair parts, and equipment needed to service the implement.

Serial Number

Model No. _____ Serial No. _____

For quick reference and prompt service, record model number and serial number in the spaces provided above and again on warranty page 41. Always provide model number and serial number when ordering parts and in all correspondences with your Land Pride dealer. Refer to Figure 1 for location of your serial number.

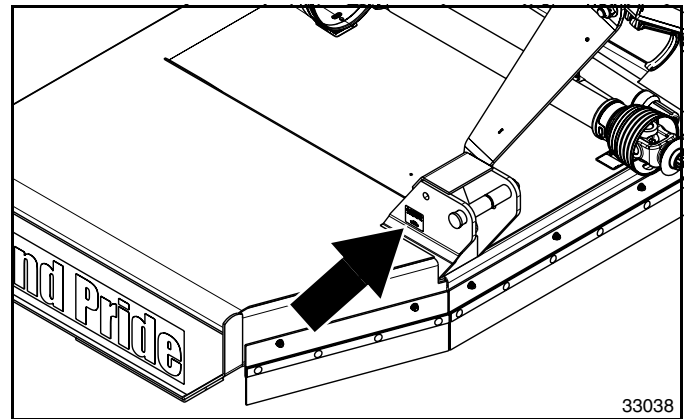

Figure 1

Further Assistance

Your dealer wants you to be satisfied with your new Rotary Cutter. If for any reason you do not understand any part of this manual or are not satisfied with the service received, the following actions are suggested:

1. Discuss the matter with your dealership service manager making sure that person is aware of any problems you may have and has had the opportunity to assist you.
2. If you are still not satisfied, seek out the owner or general manager of the dealership, explain the problem, and request assistance.
3. For further assistance write to:

Land Pride Service Department
1525 East North Street
 P.O. Box 5060
 Salina, Ks. 67402-5060

E-mail address
lp servicedept@landpride.com

Section 1: Assembly & Set-up

Tractor Requirements

Tractor horsepower and hitch category should be within the range noted below. Tractors outside the horsepower range must not be used.

- Tractor Horsepower Rating 60 to 130 HP
- Hitch Type:
 - 3-Point Category Cat II & III
 - Pull-Type Draw Bar
- PTO Speed. 540 RPM
- Hydraulic Outlets (Pull-Type) Single Outlet
- Tractor Weight See Warning Below

! WARNING

Ballast weights may need to be added to your tractor to maintain steering control. Refer to your tractor operator's manual to determine proper ballast requirements.

Torque Requirements

Refer to "Torque Values Chart" on page 40 to determine correct torque values for common bolts. See "Additional Torque Values" at bottom of chart for exceptions to standard torque values.

Uncrating Instructions

! WARNING

Always secure cutter with an overhead crane, fork lift, or other suitable lifting device before removing hardware bags, shipping components, bands, lag screws, and hitch pins. The cutter can suddenly fall causing serious injury or death.

1. Secure cutter with a hoist or other lifting device before removing shipping hardware.

IMPORTANT: The rear chain guard is shipped attached to the underside of the deck and must be removed before putting cutter into service or the cutting blades will hit the guard.

2. Unbolt rear chain guard from underside of deck. Keep all attaching hardware for reassembly later.
3. Cut shipping straps securing driveline and hitch straps to the shipping crate. Remove driveline from shipping crate and pivot hitch straps down gently.
4. Remove lag screws securing front face of cutter to the crate.
5. Using lifting device, remove tension on hitch pins securing clevis plates to shipping crate.
6. Remove hitch pins from clevis plates and lift cutter from shipping crate.

NOTE: When lowering cutter onto the working area, keep hitch straps from falling onto the manual tube and breaking the tube.

7. Gently lower cutter onto the working area. Be careful not to allow hitch straps to fall onto the manual tube.

Gearbox Vented Dipstick

Refer to Figure 1-1:

IMPORTANT: Rotary Cutters are shipped with a solid plug in the gearbox to prevent loss of oil during shipping and handling. The solid plug on top of the gearbox must be replaced with a vented dipstick. Do not operate cutter without vented dipstick installed.

A vented dipstick is shipped loose and packaged with the Operator's Manual. Remove temporary solid plug from top of gearbox and replace with vented dipstick. See your nearest Land Pride dealer if dipstick is missing.

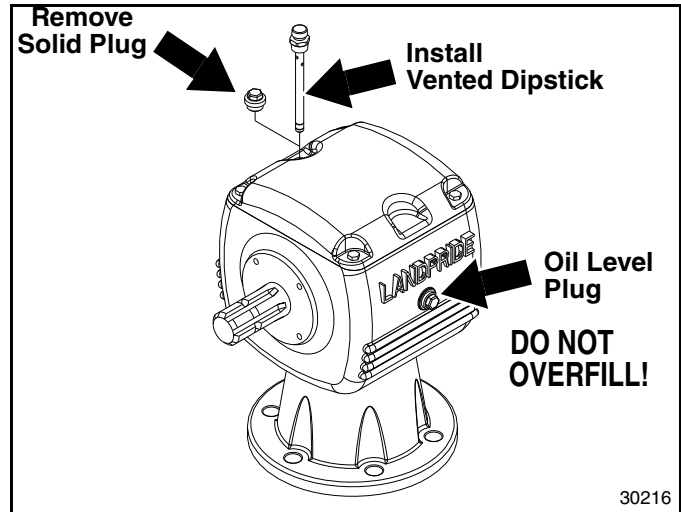

**Gearbox Vented Dipstick Installation
Figure 1-1**

Section 1: Assembly & Set-up

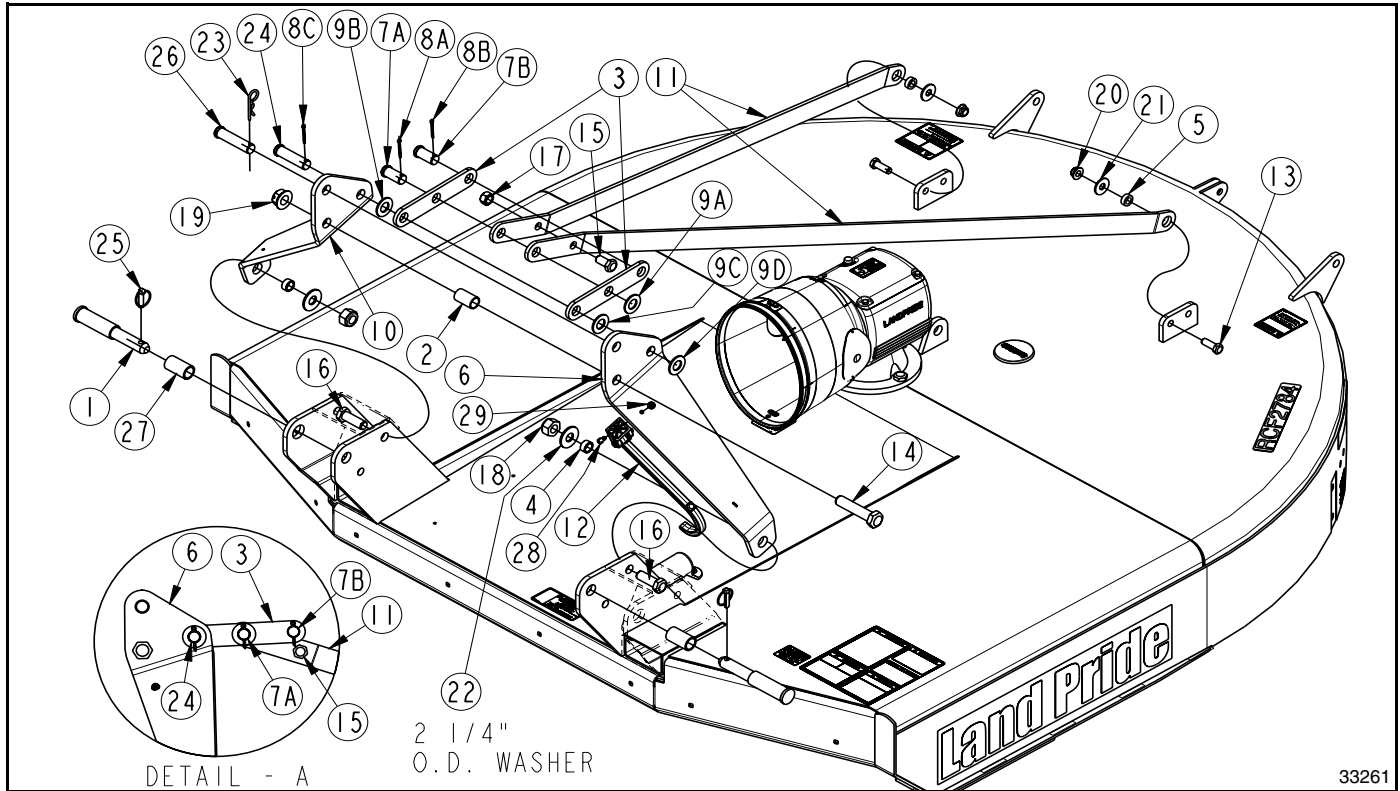

Hitch Assembly
Figure 1-2

3-Point Cutter Assembly & Set-up

The following instructions are for assembling the 3-Point cutter. See page 14 for “Pull-Type Cutter Assembly & Set-up” instructions.

3-Point Hitch



WARNING

Always secure cutter with an overhead crane, fork lift, or other suitable lifting device before removing hardware bags, shipping components, bands, lag screws, and hitch pins. The cutter can suddenly fall causing serious injury or death.

Refer to Figure 1-2:

1. Attach right and left-hand hitch straps (#6 & #10) to cutter deck with 7/8"-9 x 2 1/2" GR5 bolts (#16), bushings (#4), 2 1/4" O.D. flat washers (#22), and nylock hex nuts (#18). Tighten nylock nuts to the correct torque.
2. Attach driveline hook (#12) to hitch strap (#6) using 5/16"-18 x 1 1/4" bolt (#28) and nut (#29).
3. Bolt left and right-hand hitch straps together with 1"-8 x 4 1/2" GR5 cap screw (#14), bushing (#2), and hex flange lock nut (#19). Tighten lock nut to the correct torque.
4. Attach long rear braces (#11) to rear deck lugs in the holes shown with 5/8"-11 x 1 3/4" GR5 hex head cap screws (#13), bushings (#5), flat washers (#21), and hex flange lock nuts (#20). Tighten lock nuts to the correct torque.

5. Bolt long rear braces (#11) together with 5/8"-11 x 1 1/2" GR5 cap screw (#15) and hex lock nut (#17). Tighten lock nut to the correct torque.
6. Insert 1" x 2" clevis pin (#7B) through rear holes in short braces (#3) and secure with cotter pin (#8B). Bend one or both legs of cotter pin around clevis pin to retain cotter pin.
7. Attach long rear braces (#11) to short rear braces (#3) by inserting 1" x 2" clevis pin (#7A) through middle hole in short rear brace (#3), both long rear braces (#11), middle hole of short rear brace (#3), and flat washer (#9A). Secure clevis pin with cotter pin (#8A). Bend one or both legs of cotter pin around clevis pin to retain cotter pin.
8. Rotate short rear braces (#3) around until clevis pin (#7B) is above long rear braces (#11) as shown in Detail-A.
9. Attach short rear braces to right and left-hand hitch straps by inserting clevis pin (#24) through hitch strap (#10), flat washer (#9B), both short rear braces (#3), flat washer (#9C), hitch strap (#6), and flat washer (#9D). Secure clevis pin (#24) with cotter pin (#8C). Bend one or both legs of cotter pin around clevis pin to retain cotter pin.
10. Attach clevis pin (#26) to right and left-hand hitch straps (#10 & #6) as shown. Secure clevis pin with hairpin cotter (#23).
11. Attach hitch pins (#1) and 2 1/2" long adapter bushings (#27) to 3-Point clevis as shown. Secure hitch pins with linchpins (#25).

Section 1: Assembly & Set-up

3-Point Single Tailwheel Option

Refer to Figure 1-3:

1. Attach tailwheel A-frame (#1) to inside of rear deck lugs with 5/8"-11 x 2" GR5 cap screws (#2A), and hex nylock nuts (#5). Draw nylock nut up snug, do not tighten.
2. Install two 2 1/4" OD machine washers (#6A & #6B) onto tailwheel spindle (#9).
3. Insert tailwheel spindle (#9) into pivot tube of A-frame (#1) and install machine washer (#6C) over tailwheel spindle. Secure tailwheel with 3/8" x 2 1/2" roll pin (#8).
4. Attach bottom hole of tailwheel adjustment bar (#3) to deck rear with 5/8"-11 x 2" GR5 cap screw (#2C), and hex nylock nut (#5). Draw nylock nut up tight, do not torque tight.
5. Attach tailwheel adjustment bar (#3) to A-frame (#1) with 5/8"-11 x 2" GR5 cap screw (#2B), spring lock washer (#7), and hex nut (#4). Tighten hex nut until lock washer (#7) is squeezed flat.

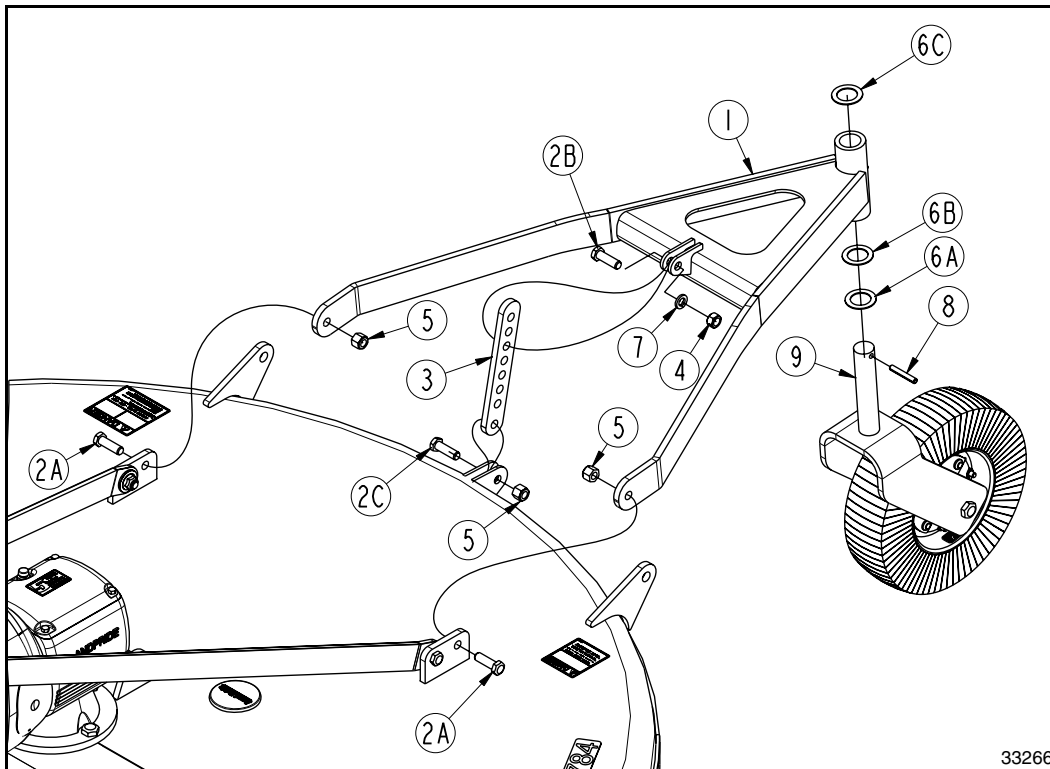

Single Tailwheel Assembly
Figure 1-3

Section 1: Assembly & Set-up

3-Point Dual Tailwheel Option

Refer to Figure 1-4:

1. Attach tailwheel frame (#1) to outside of rear deck lugs with 5/8"-11 x 1 3/4" GR5 cap screws (#3), and hex flange nylock nuts (#7). Draw nylock nut up snug, do not tighten.
2. Install two 2 1/4" OD machine washers (#9A & #9B) onto tailwheel spindle (#11).
3. Insert tailwheel spindle (#11) into pivot tube of tailwheel frame (#1) and install machine washer (#9C) over tailwheel spindle. Secure tailwheel with 3/8" x 2 1/2" roll pin (#10).
4. Attach bottom hole of tailwheel adjustment bar (#2) to deck rear with 5/8"-11 x 2" GR5 cap screw (#4A), and hex nylock nut (#6). Draw nylock nut up tight, do not torque tight.
5. Attach tailwheel adjustment bar (#2) to tailwheel (#1) with 5/8"-11 x 2" GR5 cap screw (#4B), spring lock washer (#8), and hex nut (#5). Tighten hex nut until lock washer (#8) is squeezed flat.

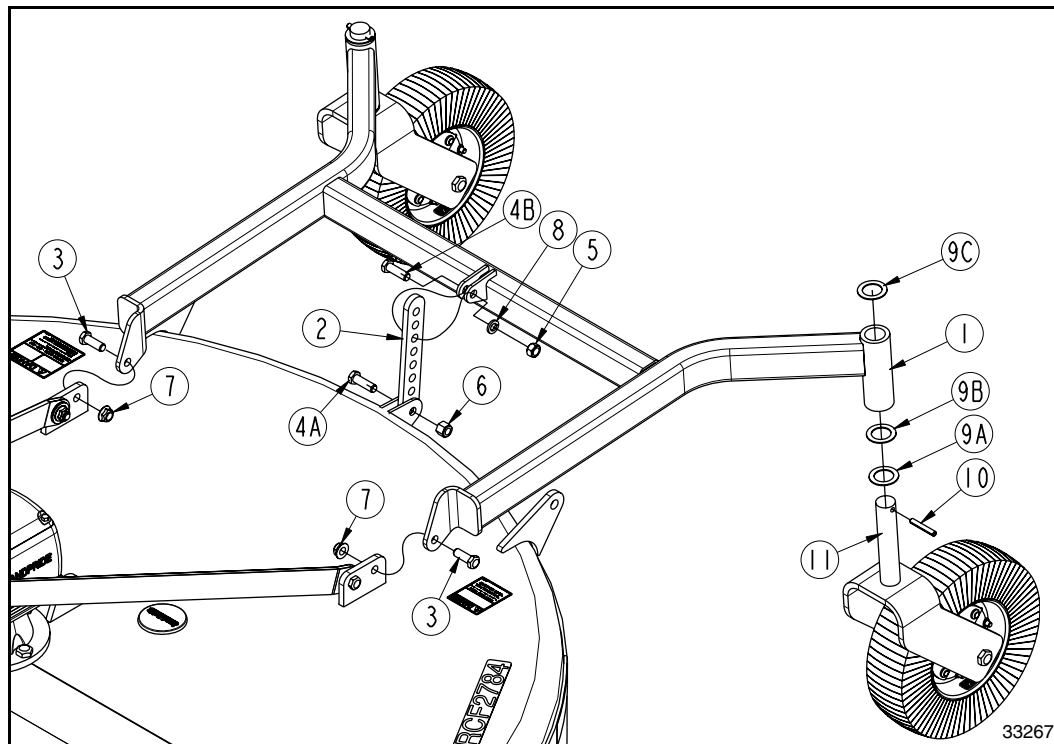

Dual Tailwheel Assembly
Figure 1-4

Section 1: Assembly & Set-up

3-Point Tractor Hook-up

Refer to Figure 1-5:

DANGER

A Crushing Hazard exists when hooking-up equipment to a tractor. Do not allow anyone to stand between tractor and implement while backing-up to implement. Do not operate hydraulic 3-point lift controls while someone is directly behind tractor or near implement.

NOTE: Driveline installation instructions will follow after hooking-up cutter to tractor. This is because the distance between tractor PTO shaft and gearbox input shaft can vary from tractor to tractor.

NOTE: Land Pride's QH20 Cat. II Quick Hitch can be attached to the tractor to provide quick and easy 3-Point hook-up and detachment. See your nearest Land Pride dealer to purchase a QH20 Quick Hitch.

A tractor with 3-Point Category II or III hitch is required. The lower 3-Point arms must be stabilized to prevent side-to-side movement. Most tractors have sway blocks or adjustable chains for this purpose.

1. Slowly back tractor to the Rotary Cutter while using tractor's 3-Point hydraulic control lever to align lower 3-Point arm hitch holes with clevis hitch pin holes.
2. Engage tractor park brake, shut tractor engine off and remove key before dismounting from tractor.

NOTE: Adapter bushings (#13) are used if tractor 3-Point hitch is Cat. III. The bushing can also be used when using a Quick Hitch.

3. Attach lower 3-Point arms to clevises with hitch pins (#1) and if required adapter bushings (#12). Secure hitch pins with linch pins (#6).
4. Connect upper center 3-Point link hitch hole to upper hitch with clevis pin (#7) and hairpin cotter (#5).

5. Return to tractor and slowly and carefully raise and lower cutter to ensure drawbar, tires, and other equipment on the tractor do not contact cutter frame. Move or remove drawbar if it interferes with cutter.
6. Manually adjust one of the lower lift arms up or down to level the Rotary Cutter from left to right.
7. Manually adjust length of top-center-link to align center hitch pin vertically above lower hitch pins. Final deck leveling adjustments will be made later.
8. The tractor's lower 3-Point arms should be adjusted for lateral float. Please consult your tractor's manual for adjusting instructions.

Driveline Installation

DANGER

Do not engage tractor PTO while hooking-up and unhooking driveline or while someone is standing near the driveline. A person's body and/or clothing can become entangled in the driveline resulting in serious injury or death.

DANGER

All guards and shields must be installed and in good working condition at all times during cutter operation.

WARNING

Always disengage PTO, put tractor in park or set park brake, shut tractor engine off, remove ignition key, and wait for blades to come to a complete stop before dismounting tractor.

WARNING

Do not use a PTO adapter. A PTO adapter will increase strain on the tractor's PTO shaft resulting in possible damage to shaft and driveline. It will also defeat the purpose of the tractor's master shield and could cause bodily injury or death.

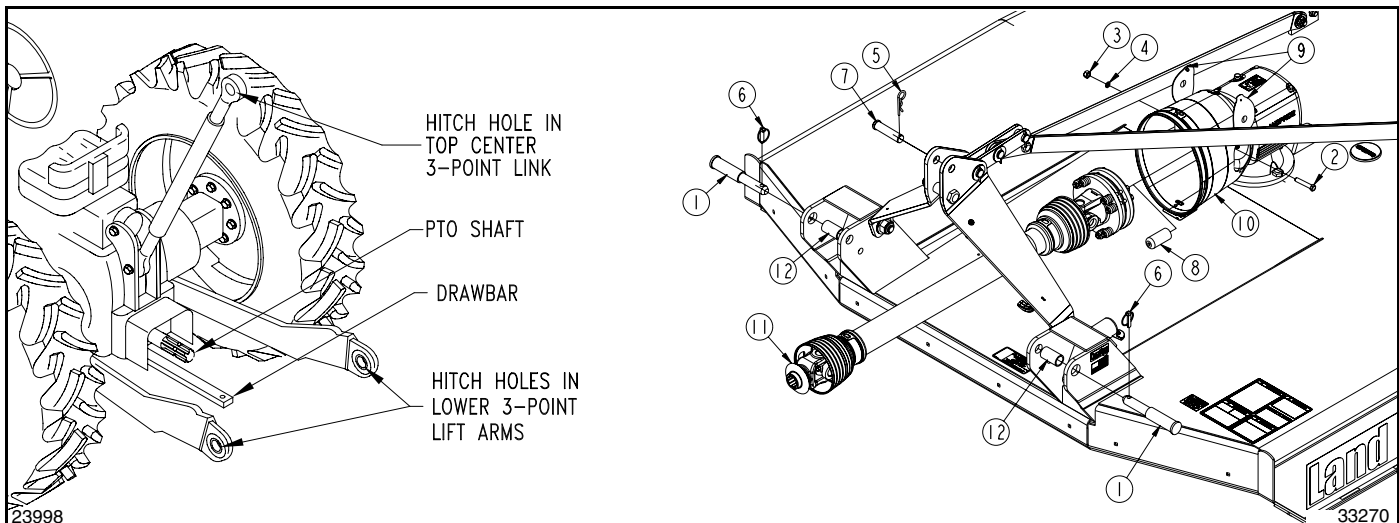

Driveline Installation
Figure 1-5

Section 1: Assembly & Set-up

WARNING

Do not over-speed PTO or machine breakage may result. Some tractors are equipped with multispeed PTO ranges. Be certain your tractor's PTO does not exceed 540 RPM.

IMPORTANT: An additional driveline may be required if cutter is to be used on more than one tractor, especially if a Quick Hitch is used.

The driveline must be lubricated before putting it into service. Refer to “**Lubrication Points**” on page 34.

The tractor's PTO shaft and cutter gearbox shaft must be aligned and level with each other when hooking-up the driveline to the tractor.

Refer to Figure 1-5 on page 12:

1. Park tractor on a level surface. Slowly engage tractor 3-Point lift lever to raise cutter until gearbox input shaft is in line and level with the tractor PTO shaft.
2. Place gear selector in park, set park brake, shut tractor off and remove switch key.
3. Support cutter deck at this height with support jacks or blocks to keep cutter from drifting down.
4. Remove rubber protective sleeve (#8) from gearbox input shaft and discard.
5. Unsnap one end of access doors (#9) and rotate doors open.
6. Slide slip-clutch end of driveline (#11) onto gearbox input shaft until hole in driveline yoke aligns with groove in gearbox shaft. Insert M12 x 1.25 x 65mm GR8 bolt (#2) and secure with flat washer (#4) and hex nylock nut (#3). Tighten nylock nut to the correct torque.
7. Push/pull on driveline yoke to be sure it is securely fastened to the gearbox shaft.
8. Rotate access doors (#9) closed and snap in place.
9. Pull back on driveline yoke collar (#11) and push driveline yoke onto the tractor PTO shaft. Release pull collar and continue to push driveline yoke forward until pull collar locks in place.
10. Move driveline yoke back and forth several times to make sure yoke is locked in place. If driveline yoke will not lock in place, skip to “**Check Driveline Collapsible Length**” on this page.
11. Continue with “**Check Driveline Collapsible Length**”.

Check Driveline Collapsible Length

IMPORTANT: A driveline that is too long can bottom out causing structural damage to tractor and cutter. Always check driveline collapsed length during initial setup, when connecting to a different tractor, and when alternating between using a quick hitch and a standard 3-point hitch. More than one driveline may be required to fit all applications.

1. Make sure driveline is properly installed and level before checking driveline collapsible length. Refer to “**Driveline Installation**” instructions on page 12.

Refer to Figure 1-6:

2. With driveline level, measure (“**B**” dimension) back from universal joint shield to end of outer driveline shield as shown in Figure 1-6.
3. If measurement is 1” or more, skip to “**Check Driveline Interference**” on page 14. If measurement is less than 1”, shorten driveline using instructions provided below.

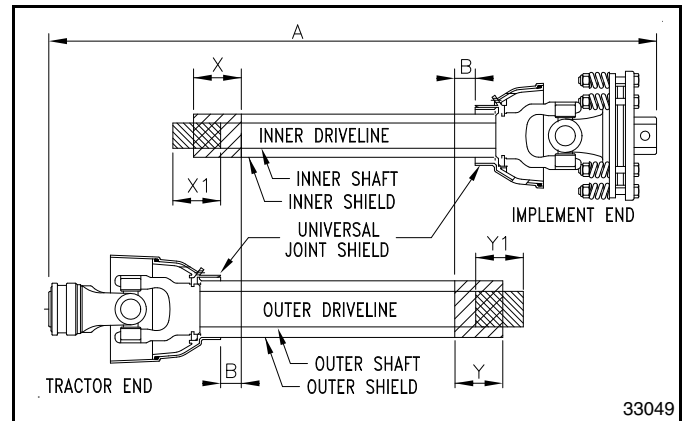

Driveline Shortening
Figure 1-6

Shorten Driveline

Refer to Figure 1-6:

Be sure to check driveline collapsed length first. If required, shorten driveline.

1. Unhook driveline from tractor PTO shaft. Pull outer and inner drivelines apart.
2. Reattach outer driveline to tractor PTO shaft. Pull on inner and outer driveline yokes to be sure universal joints are properly secured.
3. Hold inner and outer drivelines parallel to each other:
 - a. Measure 1” (“**B**” dimension) back from outer driveline universal joint shield and make a mark at this location on the inner driveline shield.
 - b. Measure 1” (“**B**” dimension) back from the inner driveline universal joint shield and make a mark at this location on the outer driveline shield.
4. Remove driveline from tractor PTO shaft and gearbox shaft.
5. Measure from end of inner shield to scribed mark (“**X**” dimension). Cut off inner shield at the mark. Cut same amount off the inner shaft (“**X1**” dimension).
6. Measure from end of outer shield to scribed mark (“**Y**” dimension). Cut off outer shield at the mark. Cut same amount off the outer shaft (“**Y1**” dimension).
7. Remove all burrs and cuttings.
8. Continue with “**Check Driveline Maximum Length**” on page 14.

Section 1: Assembly & Set-up

Check Driveline Maximum Length

Refer to Figure 1-7:

The driveline maximum allowable length must, when fully extended, have a minimum overlap of profile tubes by not less than 1/2 the free length with both inner and outer profile tubes being of equal length.

1. Apply multi-purpose grease to the inside of the outer shaft and reassemble the driveline.
2. Assemble the two driveline profiles together with just 1/2 overlapping of the profile tubes as shown. Once assembled, measure and record maximum allowable length here. _____

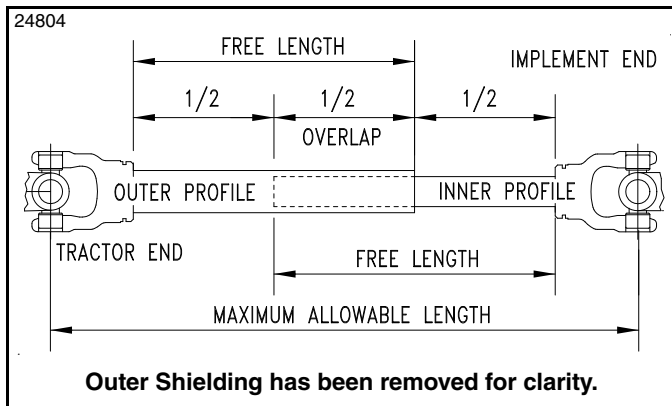

Driveline Maximum Extended Length
Figure 1-7

3. Continue with “Check Driveline Interference” on right side of this page.

Check Driveline Interference

1. Make certain driveline yokes are properly attached.
2. Start tractor and raise Rotary Cutter just enough to remove support blocks from under the cutter.
3. Slowly engage tractor hydraulic 3-Point control lever to lower cutter while checking for sufficient drawbar clearance. Move drawbar ahead, aside, or remove if required.

Refer to Figure 1-8:

IMPORTANT: Avoid premature driveline breakdown. A driveline that is operating **must not exceed** an angle of 25 degrees up or down while operating 3-point lift.

4. With PTO off, raise implement fully up to make the following checks below. If driveline exceeds any of the limits listed, set tractor 3-Point lift limiter at a height that will keep the driveline within its lift limits and to avoid premature driveline breakdown.
 - Driveline does not exceed 25° up.
 - Driveline does not exceed maximum allowable length recorded in step 2 under “Check Driveline Maximum Length”.

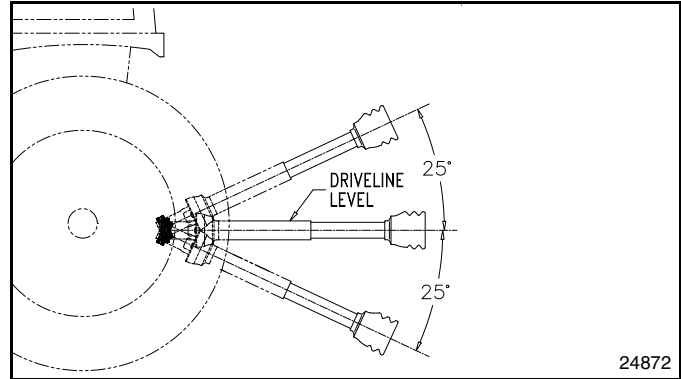

Maximum PTO Driveline Movement During Operation
Figure 1-8

Pull-Type Cutter Assembly & Set-up

The following instructions are for assembling the Pull-Type cutter. See page 9 for “3-Point Cutter Assembly & Set-up” instructions.

Hitch Assembly

The tongue, drivelines, dual tailwheel axle, and ratchet jack option or hydraulic cylinder option will need to be assembled to the deck.

Refer to Figure 1-9 on page 15:

1. Discard 2 1/2" long bushing (not shown) shipped with hitch pins (#1). Attach tongue (#7) to deck with hitch pins (#1) and 1" long spacers (#4). Secure hitch pins with linchpins (#21).

IMPORTANT: Be sure bearing lock collar in bearing support assembly (#5) is facing driveline (#25).

2. With bearing lock collar facing driveline (#25), attach bearing support assembly (#5) to tongue (#9) with bushings (#6), flat washers (#18), lock washer (#19), hex nut (#15), and 5/8"-11 x 7 1/2" GR5 hex head cap screw (#10). Tighten hex nut to the correct torque.
3. Attach spring hose loop mounting bracket (#3) to the right-hand clevis with 3/8" -16 x 1" GR5 hex head cap screw (#11) and lock nut (#16). Tighten lock nut to the correct torque.
4. Attach spring hose loop (#22) to spring hose loop mounting bracket (#3) with 3/8" -16 x 1" GR5 cap screw (#9), flat washer (#17), and lock nut (#13). Tighten lock nut to the correct torque.
5. Attach parking jack support stob (#2) to the left-hand clevis lower hole with 3/4"-10 x 1 3/4" GR5 hex head cap screw (#12) and lock nut (#16). Tighten lock nut to the correct torque.
6. Attach parking jack (#27) to stob on tongue with detent hitch pin (#28). Make certain detent hitch pin is fully inserted.

Section 1: Assembly & Set-up

Driveline Installation

Refer to Figure 1-9:



WARNING

Do not use a PTO adapter. A PTO adapter will increase strain on the tractor's PTO shaft resulting in possible damage to shaft and driveline. It will also defeat the purpose of the tractor's master shield and could cause bodily injury or death.

1. Remove rubber protective sleeve (#23) from gearbox input shaft and discard.
2. Remove coupling bolt (#8) from end of slip-clutch.
3. Unsnap one end of both access doors (#26) and rotate doors open.
4. Slide slip-clutch end of driveline onto gearbox input shaft until holes in slip-clutch align with notch in gearbox input shaft.
5. Secure driveline (#25) to gearbox input shaft with coupling bolt (#8), spring lock washer (#20), and hex nut (#14). Tighten hex nut to the correct torque.
6. Move slip-clutch back and forth several times to make certain it is locked onto the gearbox shaft.
7. Rotate access doors (#26) closed and snap in place.
8. Insert jackshaft end of driveline (#25) through bearing in bearing support assembly (#5).
9. Pull bearing in bearing support assembly (#5) against driveline (#25) and tighten set screw in bearing collar against driveline jackshaft.
10. Attach driveline (#24) to jackshaft on driveline (#25) by pulling back on pull collar (#29) and pushing yoke onto the jackshaft. Release pull collar and continue to push yoke forward until pull collar locks in place.
11. Move driveline yoke back and forth several times to make sure yoke is locked in place.

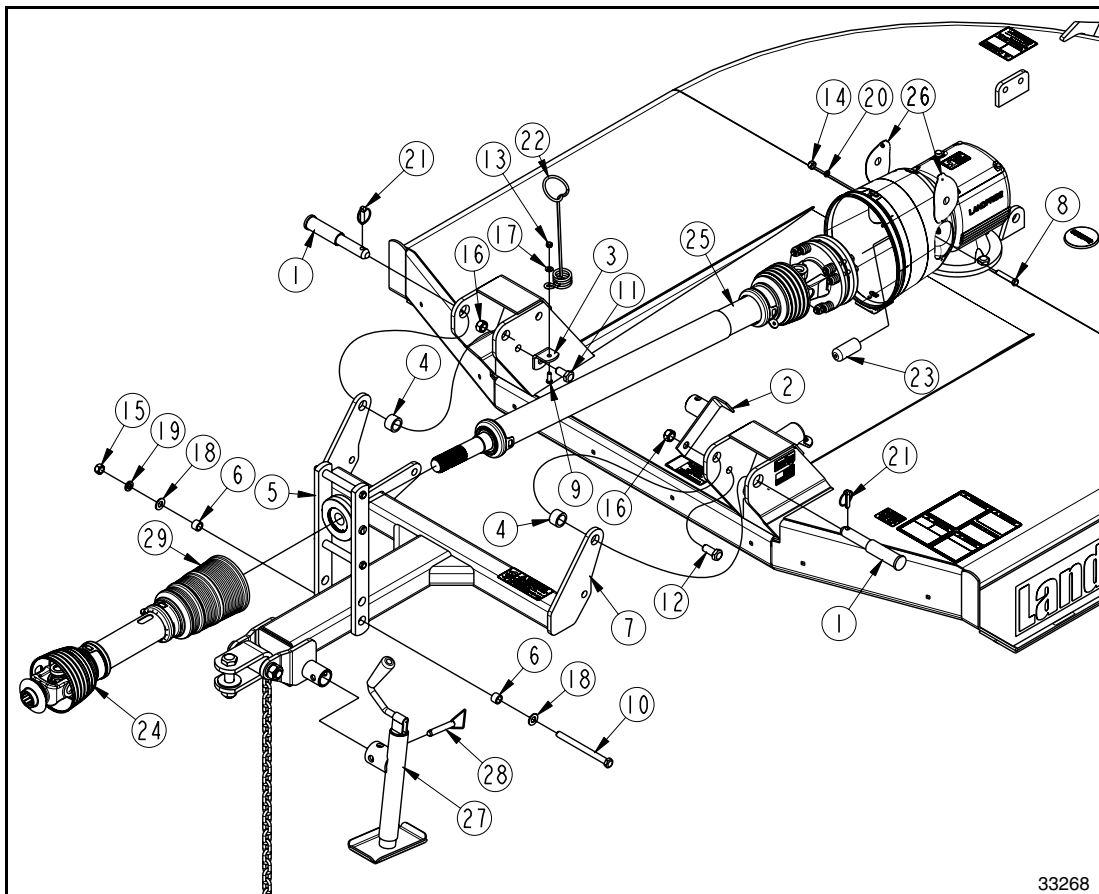

Trail-Type Tongue Assembly
Figure 1-9

Section 1: Assembly & Set-up

Axle Assembly

Refer to Figure 1-10:

NOTE: Tailwheel on right-hand side is not shown to allow easier viewing of balloons.

1. Install tailwheels (#26) to axle frame (#5) with hex flange lock nuts (#14). Tighten lock nuts to the correct torque.
2. Attach axle frame (#5) to rear deck lugs with 3/4"-10 x 2 1/2" GR5 cap screws (#10), spacer tubes (#1), flat washers (#15), and lock nuts (#11). Tighten nuts to the correct torque.
3. Install ratchet jack (#7) or hydraulic cylinder (#8) to deck assembly as follows:

Ratchet Jack Installation:

- a. Attach base of ratchet jack (#7) to mounting lugs behind gearbox with 1" x 4 3/4" clevis pin (#21) as shown. Secure clevis pin with hairpin cotter (#19).
- b. Operate ratchet lever to extend or shorten ratchet jack until spring cushioned end of ratchet jack aligns with hole in axle frame (#5).
- c. Insert 1" x 3 3/16" clevis pin (#20) and secure with hairpin cotter (#19).

Hydraulic Cylinder Installation:

- a. Screw vent plug (#9) into port on rod end of cylinder (#8) until tight.
 - b. Screw O-ring end of 9/16" straight adapter (#24) into port of base end of cylinder (#8) until tight.
 - c. Screw hydraulic hose (#25) to straight adapter (#24) until tight.
 - d. Attach quick coupling (coupling supplied by customer) at tractor end to hydraulic hose (#25) until tight.
 - e. Attach base end of hydraulic cylinder (#8) between and to mounting lugs behind gearbox with 1" x 4 3/4" clevis pin (#21). Secure clevis pin with hairpin cotter (#19).
 - f. Extend hydraulic cylinder until clevis on spring cushioned end (#6) straddles lug on axle frame (#5) and holes in clevis aligns with hole in axle frame lug.
 - g. Insert 1" x 2 3/4" clevis pin (#16) and secure with hairpin cotter (#19).
4. Screw coupler nut (#13) onto long leveling rod (#3) about 1 3/4".
 5. Screw jam nut (#12) onto the short leveling rod (#2) a distance of about 1 3/4".
 6. Screw short leveling rod (#2) into coupler nut (#13) until coupler nut is against jam nut (#12).

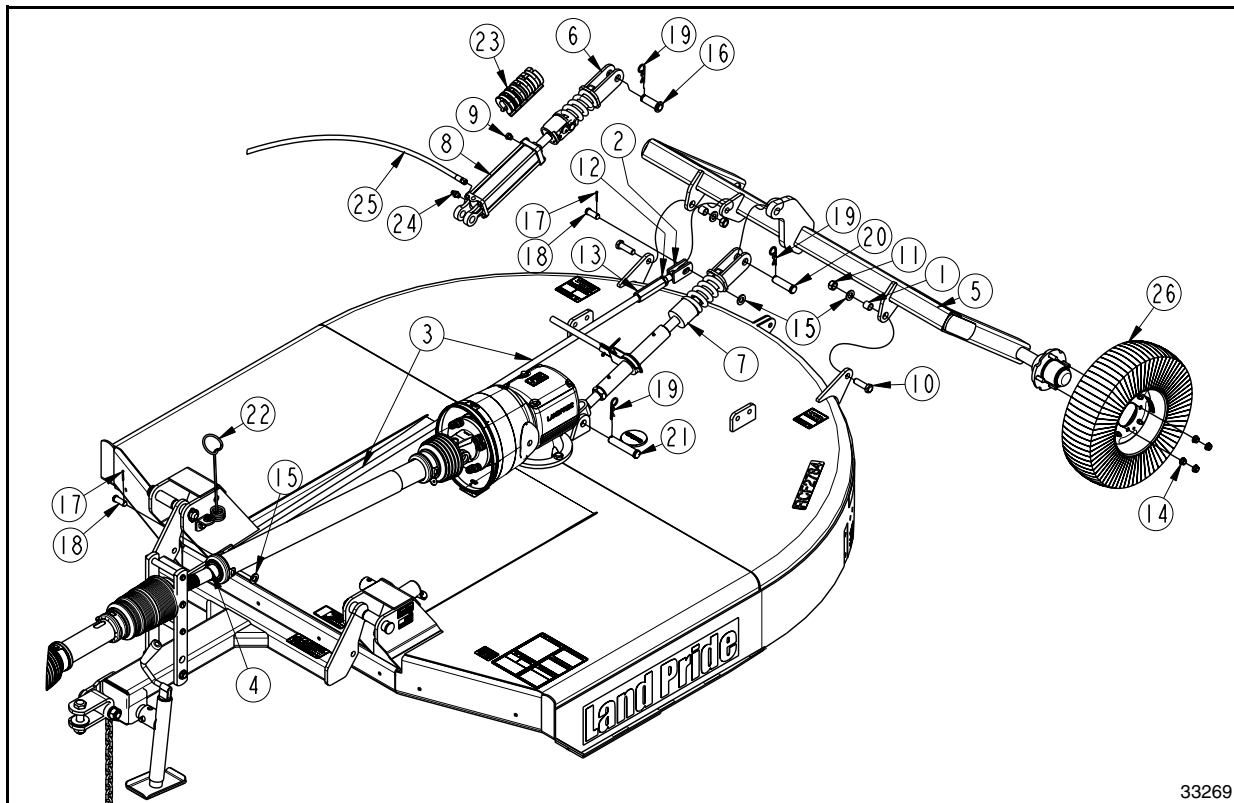

Trail-Type Axle Assembly
Figure 1-10

33269

Section 1: Assembly & Set-up

- Attach clevis end of long leveling rod (#3) to mounting bracket (#4) on the tongue with 3/4" x 1 1/2" clevis pin (#18), flat washer (#15), and cotter pin (#17). Bend one or more legs of cotter pin to keep it from falling out.
- Attach clevis end of short leveling rod (#2) to mounting lug on axle frame (#5) with 3/4" x 1 1/2" clevis pin (#18), flat washer (#15), and cotter pin (#17). Bend one or more legs of cotter pin to keep it from falling out.

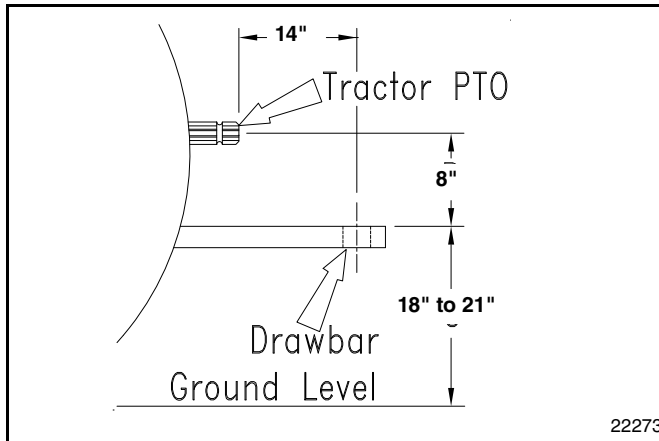

PTO to Drawbar Distance
Figure 1-11

Pull-Type Tractor Hook-up

Refer to Figure 1-11:

IMPORTANT: Tractor PTO shaft, cutter driveline, and/or gearbox can be damaged if distance from end of tractor PTO shaft to center of hitch pin hole in drawbar is not 14".

Adjust drawbar length so that center of drawbar hitch pin hole and end of tractor PTO shaft is 14".

DANGER

A Crushing Hazard exists when hooking-up equipment to a tractor. Do not allow anyone to stand between tractor and implement while backing-up to implement. Do not operate hydraulic 3-point lift controls while someone is directly behind tractor or near implement.

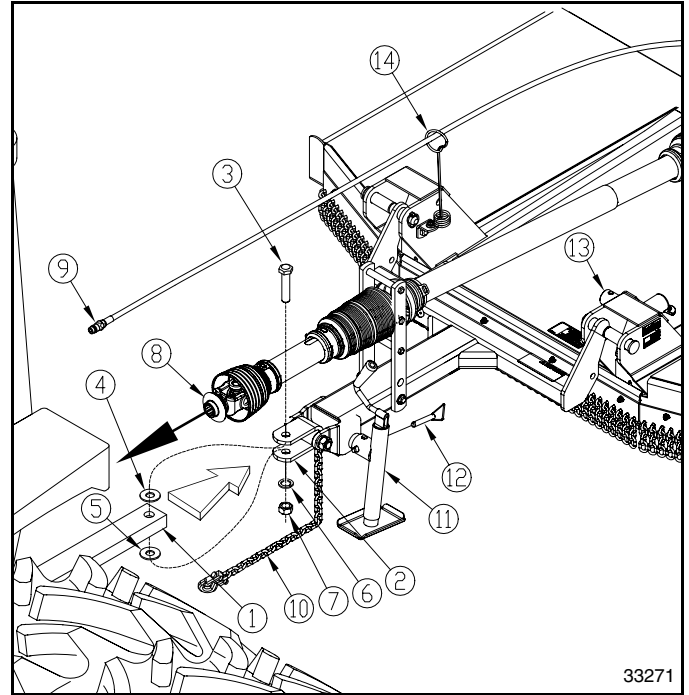

Tractor Hook-up (Standard Clevis Hitch Shown)
Figure 1-12

Refer to Figure 1-12:

IMPORTANT: Jack attachment pin must be fully inserted and secured before working on or around a cutter not hooked to the tractor drawbar.

- Make certain jack stand (#11) is properly attached to cutter hitch and properly secured with jack pin (#12).
- Back drawbar (#1) close to clevis hitch (#2).
- Drawbar should fit between upper and lower clevis hitch plates. Raise or lower jack stand (#11) to align clevis hitch (#2) with tractor drawbar (#1).
- Back tractor up to cutter hitch until holes in drawbar and clevis hitch are properly aligned.
- Attach cutter to tractor drawbar with 1"-8 x 4 1/2" GR5 cap screw (#3), two flat washers (#4 & #5) as shown, lock washer (#6), and hex nut (#7). Tighten hex nut until lock washer is squeezed flat.
- Lower jack stand (#11) until hitch weight is supported by drawbar. Protect jack stand from damage by removing it from the hitch and storing it on jack support stob (#13).
- Attach hitch safety chain (#10) to the tractor frame. Adjust chain length to remove all slack except what is necessary to permit turning. Lock chain hook securely to the safety chain.
- Pull back on driveline pull collar (#8) and push driveline onto tractor PTO shaft. Release pull collar and continue to push driveline yoke onto tractor PTO shaft until pull collar locks into place. Pull on driveline yoke to make certain yoke has locked in place.

Section 1: Assembly & Set-up

Hydraulic Hook-up

! DANGER

Hydraulic fluid under high pressure can penetrate skin. Wear protective gloves and safety glasses or goggles when working with hydraulic systems. Use a piece of cardboard or wood rather than hands when searching for hydraulic leaks. If hydraulic fluid is injected into the skin or eyes, it must be treated by a doctor familiar with this type of injury within a few hours or gangrene may result. **DO NOT DELAY.**

Refer to Figure 1-12 on page 17:

1. Make sure spring support loop (#14) is securely fastened to the hitch frame and fastener hardware is properly tightened.
2. Route cylinder hose (#9) through spring support loop (#14) and connect to tractor remote outlet. Do set tractor control lever in float position.
3. Check driveline for adequate clearance under all ranges of cutter height.
 - a. With driveline shaft attached to the tractor, slowly raise and lower cutter to its upper and lower limits while observing clearances between hitch and driveline.
 - b. Adjust tractor drawbar height and/or length if driveline interferes. See Figure 1-11 on page 17 for correct drawbar dimensions.
4. Cycle hydraulic system by extending and retracting lift cylinder several times. It may be necessary to purge the hydraulic system of trapped air if operation is sluggish. See “Purge Hydraulic System” below.

Purge Hydraulic System

! DANGER

Be sure deck is lowered to the ground and all hydraulic pressure is relieved before disconnecting or reconnecting hydraulic line and/or fittings between Rotary Cutter and tractor hydraulic system.

1. With deck skid shoes resting firmly on the ground, shut tractor off, and move hydraulic control lever back and forth to relieve all hydraulic pressure in the hydraulic system.
2. Loosen hydraulic hose fitting at the hydraulic cylinder slightly to allow air and fluid to escape.
3. Restart tractor and slowly activate tractor control lever to extend and retract hydraulic cylinder to purge trapped air from the hydraulic system.
4. Lower cutter down until deck skid shoes are resting firmly on the ground, shut tractor off, and move hydraulic control lever back and forth to relieve all hydraulic pressure in the hydraulic system.
5. After all air is purged from the hydraulic system and all hydraulic pressure is relieved, retighten hose fitting at the hydraulic cylinder.

Assembly of Optional Guards

! DANGER

Rotary Cutters have the ability to discharge objects at high speeds; therefore, the use of front and rear safety guards is strongly recommended when cutting along highways or in areas where people may be present.

Front Rubber Guard

Refer to Figure 1-13:

1. Install Front Rubber Guards (#1 & #2) as shown with 3/8"-16 x 1" GR5 carriage bolts (#3), and hex whiz nuts (#4).
2. Tighten nuts to the correct torque.

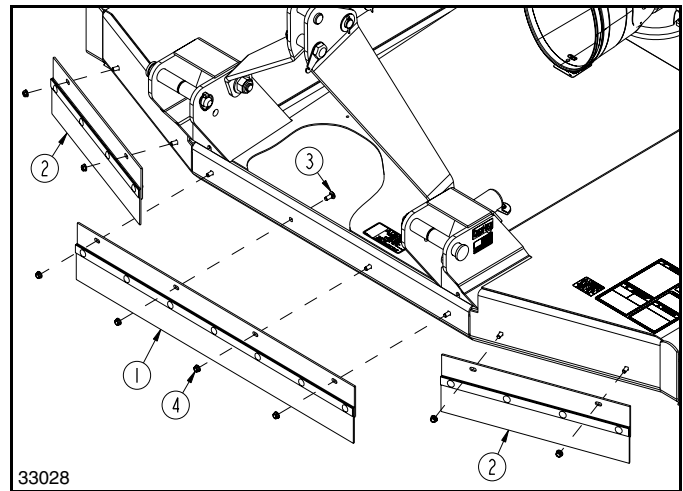

Front Rubber Guard Option
Figure 1-13

Front Single or Double Chain Guard

Refer to Figure 1-14:

1. Install front chain guards (#1 & #2) as shown with 3/8"-16 x 1" GR5 carriage bolts (#3), and hex whiz nuts (#4).
2. Tighten nuts to the correct torque.

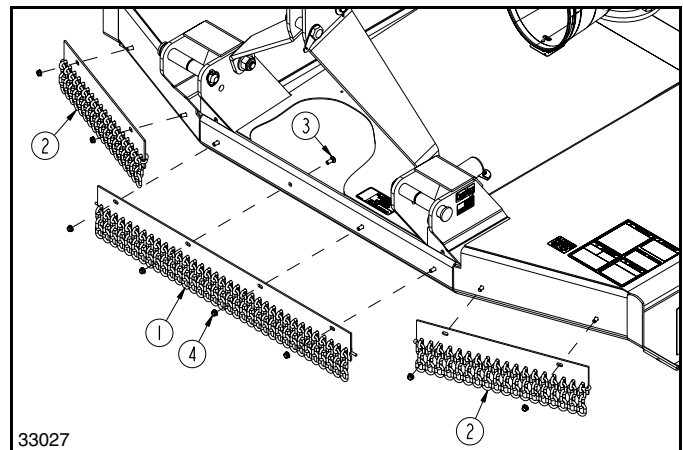

Front Single Chain Guard Option
Figure 1-14

Section 1: Assembly & Set-up

Rear Single or Double Chain Guards

Refer to Figure 1-15:

1. Install rear chain guard (#2) with four 1/2"-13 x 1" GR5 carriage bolts (#3), and hex whiz nuts (#5). Draw whiz nuts up snug, do not tighten at this time.
2. Install 1/2"-13 x 3 1/2" GR5 carriage bolts (#4), deflector spacers (#1), and hex whiz nuts (#5). Draw whiz nuts up snug.
3. Tighten all whiz nuts (#5) to the correct torque.

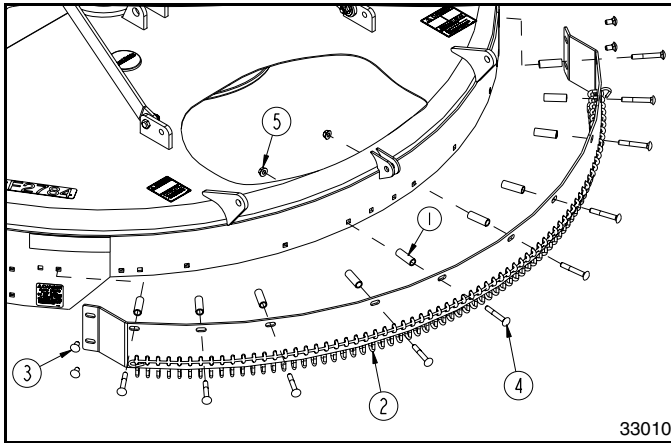

Rear Single Chain Guard Option
Figure 1-15

Section 2: Adjustments

3-Point Leveling & Cutting Height

There are four primary adjustments that should be made prior to actual field operation:

1. Deck Leveling
2. Cutting Height Adjustment
3. Single & Dual Tailwheel Adjustment
4. Center 3-Point Link Adjustment

Proper adjustment of each of these items will provide for higher efficiency, improved cutting performance, and longer blade life. Pliable tape measure, spirit or carpenter's level, set of wrenches, and protective gloves will be needed.

WARNING

Always disengage PTO, put tractor in park or set park brake, shut tractor engine off, remove ignition key, and wait for all moving parts to stop before dismounting from tractor.

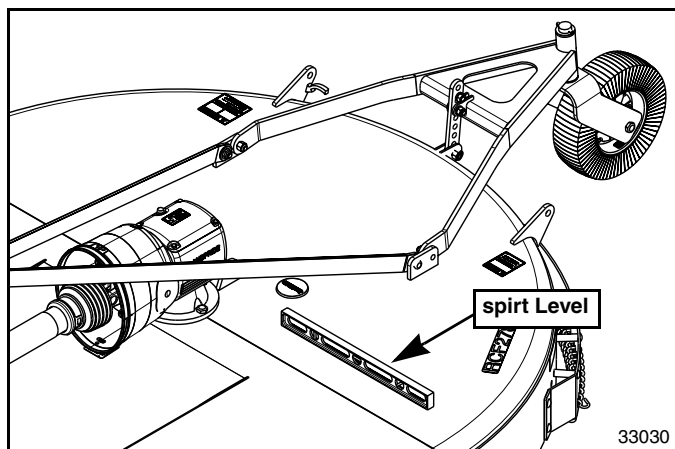

Deck Leveling
Figure 2-1

Deck Leveling

Refer to Figure 2-1:

1. Locate tractor with Rotary Cutter on a flat, level surface.
2. Use tractor's 3-Point control lever to lower cutter until tailwheel(s) makes contact with ground surface.

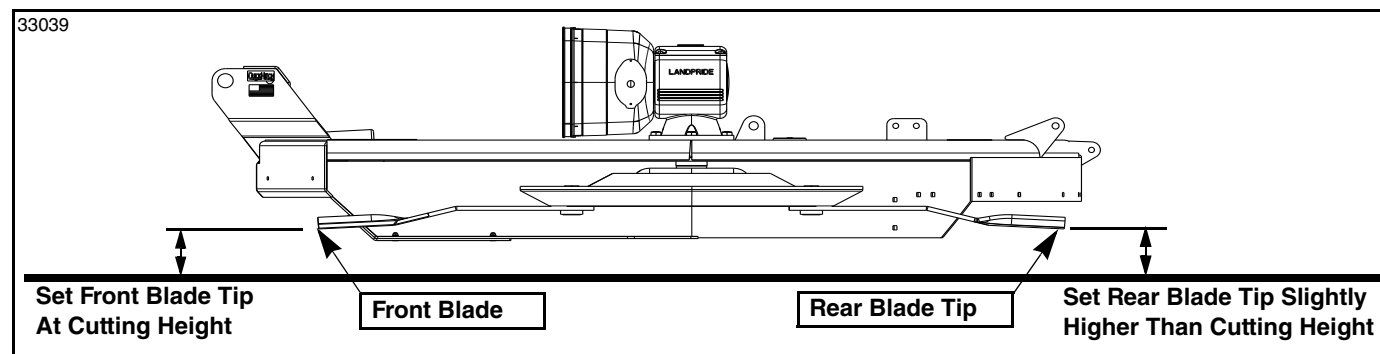

3-Point Deck Leveling & Cutting Height
Figure 2-2

3. Place a level on the cutter deck as shown. Manually adjust one or both lower 3-Point lift arms vertically until deck is level from left to right. On some tractors, only one arm can be adjusted.

Cutting Height Adjustment

Refer to Figure 2-2:

CAUTION

Avoid direct contact with cutter blades by wearing a pair of gloves. Cutter blades have sharp edges and burrs that can cause injuries.

IMPORTANT: The front blade tip should be lower than rear blade tip by approximately 1". The cutter is subject to continuous material flow under the deck if the rear blade is at the same height or lower than the front blade causing horsepower loss, grass clumps, blade wear, and frequent blade sharpening.

1. With gloves on, carefully rotate blades and stump jumper until blade tips are in the position shown.
2. Measure distance from cutting tip of front blade to ground surface. This distance is the cutting height.
3. Using tractor's 3-Point hydraulic control, raise or lower 3-Point lift arms until the front blade tip is at the desired cutting height.
4. The 3-Point center link should be loose when deck rear is supported by the tailwheel. If not, lengthen 3-Point center link until loose. Final adjustment will be made later.
5. Measure distance from cutting tip of rear blade to ground. This distance should be slightly higher than the front blade but not more than 1" higher.
6. If rear blade is lower than front blade or more than 1" higher than the front blade, then tailwheel height must be adjusted. If needed, see "Single & Dual Tailwheel Adjustment" instructions on page 21.
7. Repeat steps 1 through 6 until tailwheel and 3-Point arms are adjusted to the desired cutting height.
8. Set tractor's 3-Point hydraulic control stop once the tailwheel and 3-Point arms are adjusted properly.

Section 2: Adjustments

Single & Dual Tailwheel Adjustment

Refer to Figure 2-3 & Figure 2-4:

Instructions for adjusting 3-Point tailwheel height is the same for single and dual tailwheels. If the front blade tip is set at the desired cutting height and the back blade tip is lower, at the same height, or higher than the front blade tip by more than 1" then the tailwheel(s) must be adjusted up or down as follows:

1. Use tractor's 3-Point hydraulic control to lift cutter until tailwheel(s) (#5) is off the ground.
2. Remove hex nut (#3), lock washer (#4), and cap screw (#2).
3. Adjust tailwheel as follows:
 - To lower rear blade, lift tailwheel(s) (#5) up.
 - To raise rear blade, lower tailwheel(s) (#5) down.
4. Reattach adjustment bar (#1) with existing 5/8" cap screw (#2), lock washer (#4), and hex nut (#3). Tighten nut to the correct torque.
5. Readjust tractor's lower 3-Point lift arms as needed. See "**Cutting Height Adjustment**" instructions on page 20.

NOTE: The following adjustments may be made if desired cutting height is located between two holes in tailwheel adjustment bar (#1).

1. Unbolt adjustment bar (#1) from tailwheel pivot frame and deck mounting lugs.
2. Turn adjustment bar upside down and reattach it to the deck mounting lugs and tailwheel pivot frame using existing hardware.
3. Repeat steps 1 thru 5 above.

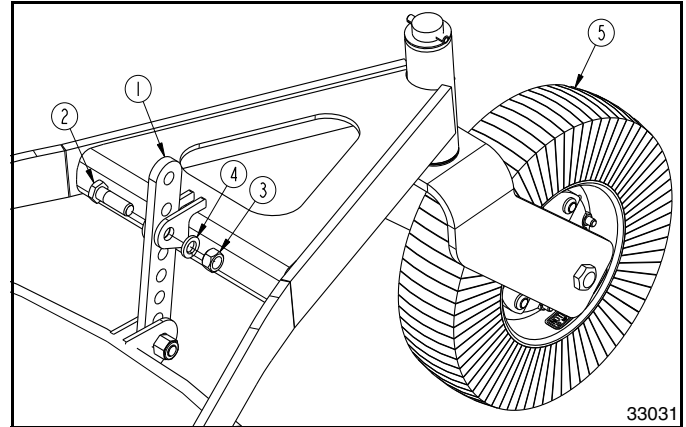

Tailwheel Height Adjustment
Figure 2-3

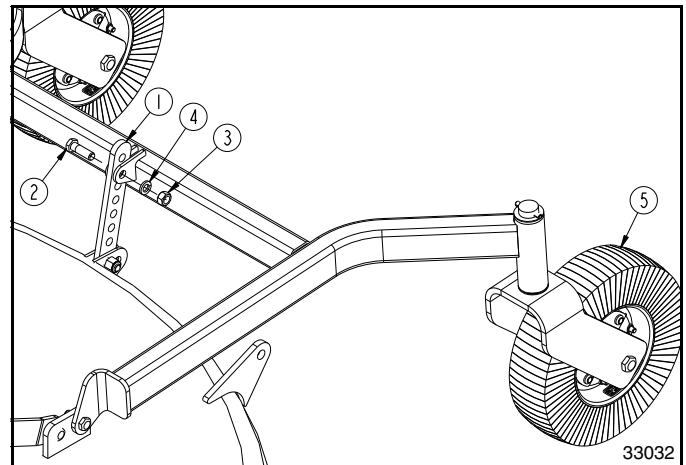

Tailwheel Height Adjustment
Figure 2-4

Center 3-Point Link Adjustment

Refer to Figure 2-5:

NOTE: The lower bolted-on-bushing in the center hitch is used with a quick hitch attachment.

1. Lower cutter deck to a preset cutting height.
2. Adjust length of center 3-Point link until upper center hitch pin is vertically above lower 3-Point hitch pins. This arrangement allows for optimum ground contour following performance.
3. Lock center 3-Point link in this position.

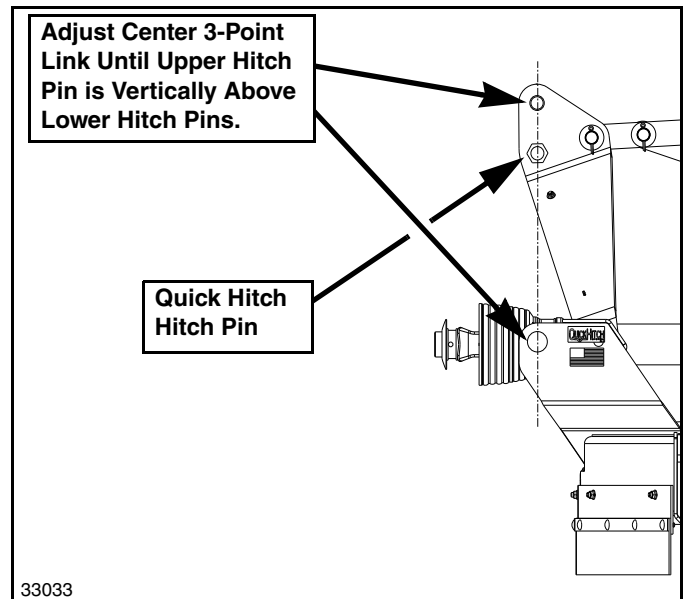

Center 3-Point Link Adjustment
Figure 2-5

Section 2: Adjustments

Pull-Type Deck Leveling & Cutting Height

There are two primary adjustments that should be made prior to actual field operation:

1. Deck Leveling
2. Cutting Height Adjustment

Proper adjustment of each of these items will provide for higher efficiency, improved cutting performance, and longer blade life. Pliable tape measure, spirit or carpenter's level, set of wrenches, and protective gloves will be needed:

WARNING

Always disengage PTO, put tractor in park or set park brake, shut tractor engine off, remove ignition key, and wait for all moving parts to stop before dismounting from tractor.

Deck Leveling

This adjustment should be made with cutter hooked to the tractor that will be used for field operations or to one having the same drawbar height and length. Adjust leveling rods as described below.

NOTE: The tip of the front blade should be lower than the tip of the rear blade. If front and rear blades are at the same height or if rear blade is lower than the front blade, then the cutter is subject to continuous material flow under the deck resulting in loss of horsepower, additional blade wear, and frequent blade sharpening.

Front To Back Deck Leveling

Refer to Figure 2-6:

1. Attach cutter to the tractor that will be pulling the cutter and position tractor and cutter on level ground.
2. With gloves on, carefully rotate blades and stump jumper until blade tips are in the position shown.
3. Using tractor control lever, adjust deck height so that the front blade tip is 3 to 4 inches above ground.

Refer to Figure 2-7 on page 23:

NOTE: Lengthen leveling rods (#1 & #2) to lower front of cutter and shorten leveling rods (#1 & #2) to raise front of cutter.

4. Measure distances the front blade and rear blade tips are off the ground. The deck is properly leveled when rear blade tip is slightly higher than front blade tip but not by more than 1".

If rear blade tip is too low:

- a. Loosen jam nut (#4) several turns.
- b. Unscrew hex coupler nut (#5) clockwise (direction shown by arrow) to raise cutter rear.
- c. Re-tighten jam nut (#4) against coupler nut (#5) when height of rear blade tip is acceptable.

If rear blade tip is too high:

- a. Loosen jam nut (#4) several turns or more.
- b. Tighten hex coupler nut (#5) counterclockwise (opposite direction shown by arrow) to lower cutter rear until height of rear blade tip is acceptable.
- c. Re-tighten jam nut (#4) against coupler nut (#5).

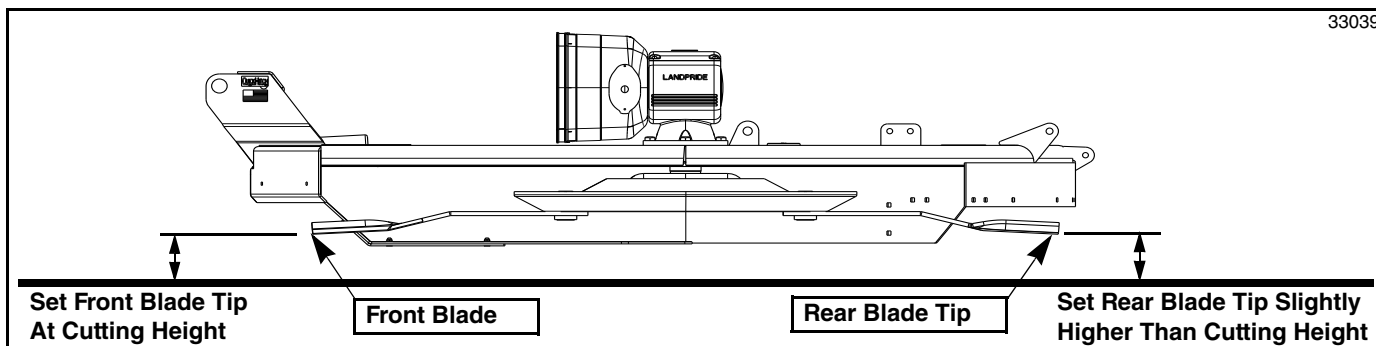

Pull-Type Deck Leveling & Cutting Height
Figure 2-6

Section 2: Adjustments

Cutting Height Adjustment

! WARNING

Always disengage PTO, put tractor in park or set park brake, shut tractor engine off, remove ignition key, and wait for all moving parts to stop before dismounting from tractor.

! CAUTION

Avoid direct contact with cutter blades by wearing a pair of gloves. Cutter blades have sharp edges and burrs that can cause injuries.

Hydraulic Cylinder Instructions

Refer to Figure 2-7:

At the front of the cutter, measure distance from cutting tip of blade to ground. This distance is the cutting height. Use tractor hydraulic cylinder control lever to change cutting height.

1. With tractor hydraulics, raise cutter fully up.
2. Remove all stroke control spacers (#6) from cylinder rod (#3) by spreading spacers apart at the break line.
3. Using tractor hydraulic cylinder control lever, lower Rotary Cutter to the desired cutting height. Measure this distance to verify cutting height is correct.
4. Select required size and number of stroke control spacers (#6) that will fill the exposed cylinder rod. The following spacers are available.
 - Two 1" spacers
 - One 1 1/4" spacer
 - One 1 1/2" spacer
 - One 1 3/4" spacer
5. Return to the tractor and raise Rotary Cutter up. Install selected size and number of stroke control spacers on the cylinder rod.
6. Lower Rotary Cutter against stroke control spacers and recheck cutting height. If needed, adjust size and quantity of stroke control spacers until desired cutting height is achieved.

NOTE: Removing spacers lowers the cutting height and adding spacers raises the cutting height.

Ratchet Jack Instructions

Refer to Figure 2-8:

At the front of the cutter, measure distance from tip of front cutting blade to ground. This distance is the cutting height. Use ratchet jack to change cutting height.

1. Raise cutter blades by setting ratchet jack lock and pumping the ratchet jack lever back and forth to lengthen ratchet jack until desired cutting height is achieved.
2. Lower cutter blades by reposition ratchet lock and pumping the ratchet jack lever back and forth to shorten the ratchet jack until desired cutting height is achieved.

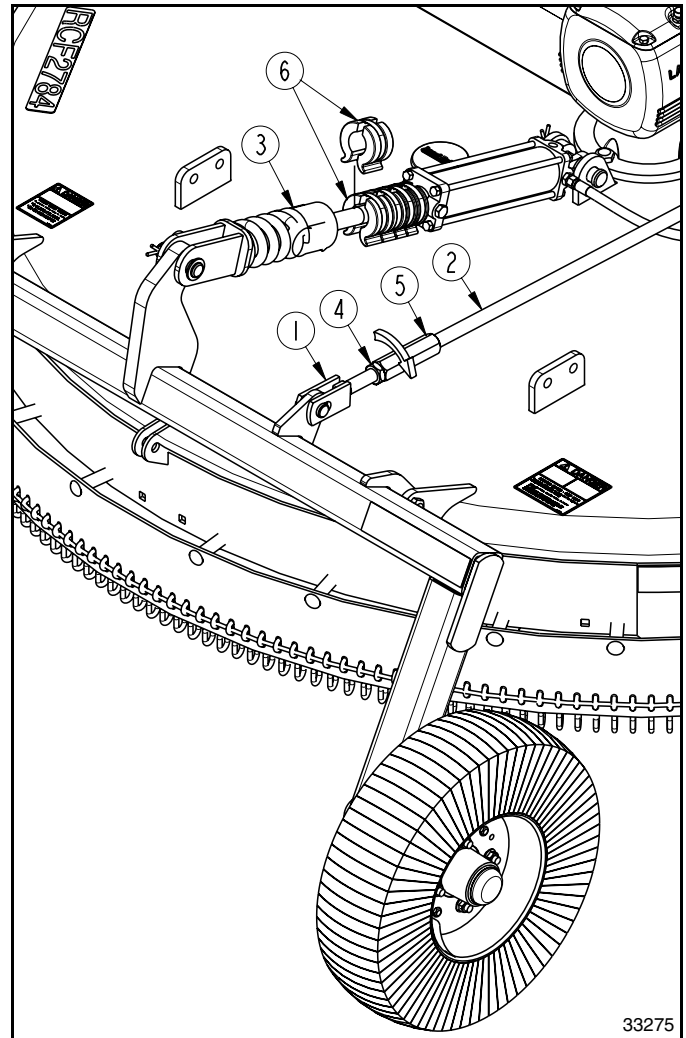

Deck Leveling & Hydraulic Height Adjustments
Figure 2-7

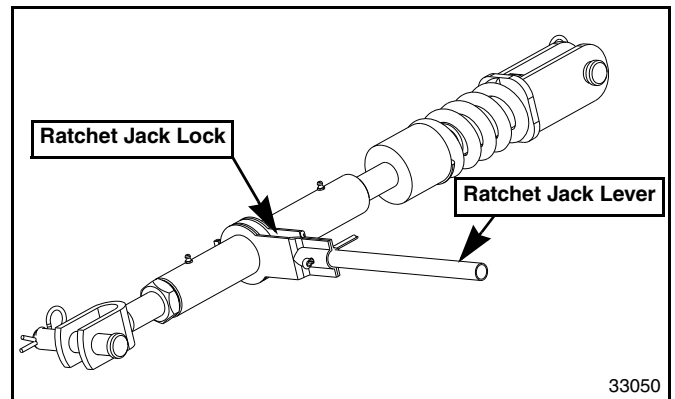

Ratchet Jack Adjustment
Figure 2-8

Section 3: Operating Instructions

Operating Checklist

Hazard control and accident prevention are dependent upon the awareness, concern, prudence, and proper training involved in the operation, transport, maintenance, and storage of the Rotary Cutter. Therefore, it is absolutely essential that no one operates the Rotary Cutter without first having read, fully understood, and become totally familiar with the Operator's Manual. Make sure the operator has paid particular attention to:

- **Important Safety Information**, pages 1 to 6
- **Section 1: Assembly & Set-up**, page 8
- **Section 2: Adjustments**, page 20
- **Section 3: Operating Instructions**, page 24
- **Section 4: Maintenance & Lubrication**, page 29

The following inspection should be performed before using the cutter.

Operating Checklist

✓	Check	Page No.
	Make sure all guards and shields are in place. Refer to "Important Safety Information".	Page 1
	Follow hook-up & driveline installation instructions. Refer to "Section 1: Assembly & Set-up".	Page 12
	Make all required adjustments. Refer to "Section 2: Adjustments".	Page 20
	Perform all required maintenance. Refer to "Section 4: Maintenance & Lubrication".	Page 29
	Lubricate cutter and driveline as needed. Refer to "Lubrication Points".	Page 34
	Lubricate gearbox and replace oil plugs properly. Refer to "Gearbox" lubrication.	Page 34
	Check cutter initially and periodically for loose bolts and pins. Refer to "Torque Values Chart".	Page 40

Safety Information

! DANGER

Do not engage tractor PTO while hooking-up and unhooking driveline or while someone is standing near the driveline. A person's body and/or clothing can become entangled in the driveline resulting in serious injury or death.

! DANGER

All guards and shields must be installed and in good working condition at all times during cutter operation.

! DANGER

Tractor PTO shield, gearbox shaft shield, and driveline shields must be secured in place when operating cutter to avoid injury or death from entanglement in driveline.

! DANGER

Always disconnect driveline from tractor PTO shaft before servicing underside of cutter. If tractor is started with PTO engaged, the cutter can cause bodily injury or death.

! DANGER

Keep others away while cutter is operating. It can discharge objects at high speeds. Therefore, the use of front and rear safety guards is required when cutting along highways and in areas where people may be present. Stop blade rotation if a bystander is within several hundred feet.

! DANGER

Do not operate a broken or bent driveline. Such drivelines can break apart while rotating at high speeds causing serious injury or death. Always remove Rotary Cutter from service until damaged drivelines are repaired or replaced.

! DANGER

Never place hands or feet under the deck or attempt to make adjustments to the cutter with PTO engaged. Cutter blades rotating at high speeds cannot be seen and are located close to the deck housing. Body extremities can be cut off instantly.

! DANGER

Do not operate and/or travel across steep inclines where a tractor can rollover resulting in serious injury or death. Consult your tractor's manual for acceptable inclines the tractor is capable of traveling across.

! DANGER

Do not use cutter as a fan. Cutting blades are not properly designed or guarded for this use. Using cutter as a fan can result in injury or death.

! WARNING

Do not use a PTO adapter. A PTO adapter will increase strain on the tractor's PTO shaft resulting in possible damage to shaft and driveline. It will also defeat the purpose of the tractor's master shield and could cause bodily injury or death.

! WARNING

Always disengage PTO, put tractor in park or set park brake, shut tractor engine off, remove ignition key, and wait for all moving parts to stop before dismantling from tractor.

! WARNING

Always disengage PTO before lifting cutter up and never operate cutter in the raised position. The cutter can discharge objects at high speeds resulting in serious injury or death.

! WARNING

Always disengage PTO before lifting cutter too high and never engage PTO with cutter raised too high. Doing so can cause rotating u-joints to break into pieces that can be thrown at high speeds causing serious injury or death.

Section 3: Operating Instructions

WARNING

Keep blade bolt access hole covered at all times except when servicing cutter blades. Make sure driveline is disconnected from the tractor before servicing cutter blades.

WARNING

Never allow riders including children on the tractor or cutter. They can fall and be ran over causing serious injury or death.

WARNING

Do not use deck as a working platform. The deck is not properly designed or guarded for this use. Using deck as a working platform could cause serious injury or death.

WARNING

Do not operate cutter with loose hardware. Loose hardware can result in a breakdown causing bodily injury or death.

WARNING

Do not use cutter to lift or carry objects, to pull fence posts, stumps or other objects, or to tow other equipment. Doing so can damage the cutter, cause serious bodily injury or death.

CAUTION

Buildup of debris around moving parts and gearboxes is a fire hazard. Keep rotating parts and gearboxes free from debris to avoid serious injury and property damage.

CAUTION

Improper oil level can cause bearing failure and be a fire hazard. Maintain proper gearbox oil level to avoid serious injury and property damage.

CAUTION

Do not exceed rated cutting capacity of your cutter. See specifications & capacities for specified cutting capacity. Exceeding ratted cutting capacities can damage drive components, cutter blades, and deck components.

CAUTION

Do not over speed PTO or machine damage may result. This cutter is designed to operate at 540 RPM rear PTO.

Inspection of Tractor & Cutter

Make the following inspections with cutter attached to a tractor, PTO disengaged and completely stopped:

1. Park tractor and cutter on a level surface.
2. Disengage PTO, place gear selector in park, set park brake, shut tractor off, and remove switch key. Make sure cutter blades have come to a complete stop before dismounting from tractor.
3. Inspect tractor safety equipment to make sure it is installed and in good working condition.
4. Inspect cutter safety equipment to make sure it is installed and in good working condition.
5. Check driveline to make certain it is securely connected to the tractor PTO shaft and cutter gearbox shaft. Also, make certain that the guards are in good working condition and in place.
6. With cutter resting on solid supports, PTO disengaged, and blade rotation completely stopped:
 - Check for and remove foreign objects wrapped around blade spindles.
 - Check for nicked, bent, broken, and worn cutting blades. Replace or sharpen blades as required. Refer to “**Cutter Blade Maintenance**” on page 30.
7. Remove solid supports from under the deck.
8. Carefully raise and lower implement to ensure that the drawbar, tires, and other equipment on the tractor do not contact cutter frame or driveline.
9. Verify cutter is set at the correct cutting height. For 3-Point cutters, see “**Cutting Height Adjustment**” on page 20 and for Pull-Type cutters, see “**Cutting Height Adjustment**” on page 23.

The remaining inspections are made by engaging the PTO to check for vibrations.

WARNING

Stop PTO immediately if vibration continues after a few revolutions during start-up and anytime thereafter. Wait for PTO to come to a complete stop before dismounting from tractor to check for probable causes. Make necessary repairs and adjustments before continuing.

IMPORTANT: Do not exceed rated cutter PTO speed. Excessive engine speed will cause damage to power train components.

10. Start tractor, set throttle to idle or slightly above idle, and slowly engage PTO. Initial start-up vibration is normal and should stop after a few revolutions. Stop PTO rotation immediately if vibration continues.
11. Once cutter is running smoothly, increase tractor PTO speed to 540 RPM. Stop PTO rotation immediately if vibration occurs.
12. Investigate cause of vibration and make repairs before putting cutter back into service.

Section 3: Operating Instructions

Transporting

WARNING

When traveling on public roads, use accessory lights, SMV sign, clean reflectors, and other adequate devices to warn operators in other vehicles of your presence. Always comply with all federal, state, and local laws.

IMPORTANT: Always disengage tractor PTO before raising cutter to transport position.

1. Make sure driveline does not contact tractor or cutter when raising cutter to transport position.
2. Reduce tractor ground speed when turning and leave enough clearance so cutter does not contact obstacles such as buildings, trees, or fences.
3. Limit transport speed to 20 mph. Transport only with a tractor of sufficient size and horse power.
4. When traveling on roadways, transport in such a way that faster moving vehicles may pass you safely.
5. Shift tractor to a lower gear when traveling over rough or hilly terrain.

Blade Engagement & Disengagement

Cutter blades can lock-up against each other during start-up and shut-down especially if the tractor's PTO engagement is "**INSTANT ON**" and "**INSTANT OFF**". Following Blade Engagement and Blade Disengagement instructions below will help eliminate blade lock up.

Blade Engagement

1. Increase throttle to a speed just enough to get the cutter started without stalling tractor while slowly engaging PTO drivelines. Use tractor's PTO soft start option if available.
2. Ensure that all power shafts are rotating and that the cutter is not vibrating excessively after ramping up to PTO speed for at least 3 seconds. If excessive vibration continues after 3 seconds at full PTO speed, disengage PTO immediately, shut down tractor, and remove switch key.
3. Check blades for a lock-up situation. Block cutter deck up before working under the unit. Unlock blades, remove support blocks, and repeat "**Blade Engagement**" instructions.

Blade Disengagement

1. Slowly decrease throttle speed until engine idle speed is reached and then disengage PTO.
2. Engage tractor park brake, shut tractor engine off and remove switch key. Stay on tractor until blades have come to a complete stop.

Field Operation

WARNING

Clear area to be cut of debris and other unforeseen removable objects before cutting. Mark any potential hazards that cannot be removed such as tree stumps, post, rocks, holes, and drop-offs with a visible flag.

IMPORTANT: Maintain correct PTO speed. Loss of PTO speed will allow blades to swing back resulting in ragged, uneven cutting. Excessive engine speed will cause damage to the power train components.

NOTE: Do not cut in wet conditions. Wet material will build up on the deck underside creating poor discharge, high wear, and additional horsepower.

Periodically disengage PTO, turn off tractor, remove key & check for objects wrapped around blade spindle. Block deck up before removing objects.

Frequently inspect cutter for loose bolts and nuts. Tighten all loose hardware as indicated in the "**Torque Values Chart**" on page 40.

NOTE: Your cutter is equipped with free swinging cutting blades to reduce shock loads when striking obstacles. However, it is best to avoid striking obstacles to extend cutter and blade life.

1. Thoroughly inspect area to be cut for debris and unforeseen objects. Mark any potential hazards.
2. Follow "**Blade Engagement**" instructions above to start cutter blades turning.
3. Optimum ground speed depends on density of material being cut, horsepower rating of tractor, and terrain. Always operate tractor at cutter's full rated PTO speed in a gear range that allows the cutter to make a smooth cut without lugging tractor down, usually between 2 to 5 mph.
4. Stop traveling and disengage PTO after the first 50 feet of cutting. Check cutter levelness and cutting height to make certain it is adjusted properly.
5. Do not engage PTO with 3-Point cutter fully raised.
6. Periodically disengage PTO, shut down tractor, remove key, and check for foreign objects wrapped around the blade spindle. Block cutter deck up before removing objects.
7. Frequently inspect cutter for loose bolts and nuts. Tighten all loose bolts and nuts as indicated in the "**Torque Values Chart**" on page 40.
8. For additional information, see "**General Operating Instructions**" on page 27.

Section 3: Operating Instructions

Unhooking the Rotary Cutter

Unhook Rotary Cutter from tractor as follows:

1. See “**Long Term Storage**” on page 33 if cutter is to be stored for a long time.
2. Park on a level solid surface and lower deck to ground level or onto support blocks.
3. Engage tractor park brake, shut tractor engine off, and remove switch key. Stay on tractor until blades have come to a complete stop.
4. Unhook cutter from tractor as follows:

3-Point Cutter:

- a. Disconnect driveline from tractor. Collapse driveline by pushing tractor end of driveline towards cutter gearbox.
- b. Rotate driveline storage hook down and place driveline in storage hook.
- c. Unhook 3-Point hitch from tractor and drive tractor forward several feet.
- d. Reinstall hitch pins, linch pins, and hair pin coters in cutter hitch for safe keeping.

Pull-Type Cutter:

- a. Attach parking jack to hitch stob with detent hitch pin. Make certain detent hitch pin is fully inserted.
- b. Adjust parking jack up until cutter weight is off tractor drawbar.
- c. Disconnect hydraulic hose and loop hose back through spring hose loop for safe keeping.
- d. Disconnect driveline from tractor. Collapse driveline by pushing tractor end of driveline towards cutter gearbox.
- e. Rotate driveline storage hook down and place driveline in storage hook.
- f. Unhook hitch safety chain from tractor.
- g. Unhook clevis from tractor and drive tractor forward several feet.
- h. Reinstall bolt, washers, lock washer, and nut in clevis for safe keeping.

General Operating Instructions

It is important that you familiarize yourself with the Operator’s Manual, completed Operator’s Checklist, properly attached cutter to your tractor, made leveling adjustments, and preset your cutting height before beginning a running operational safety check on your Land Pride Rotary Cutter.

The running operational safety check may now be done. It is important that at any time during this safety check you detect a malfunction in either the cutter or tractor that you immediately shut the tractor off, remove its key, and make necessary repairs and/or adjustments before continuing on.

Make sure before starting the tractor that the park brake is engaged, PTO is disengaged, and cutter is resting on the ground. Start tractor and set engine throttle speed at a low idle. Raise cutter with tractor’s rear hydraulic lift control lever to transport position making sure that the driveline does not bind and does not contact the cutter frame. Lower cutter to the ground and at a low engine speed engage the PTO. If everything is running smoothly at a low idle, slowly raise cutter to cutting height checking for bind or chatter in the driveline. Lower the cutter to the ground and increase the tractor’s engine RPM until it reaches the cutter full PTO operating speed of 540 RPM. If everything is still running smoothly, once more raise the cutter to cutting height to check for driveline bind or chatter. Lower the cutter to the ground, return engine to a low idle, and disengage PTO. Position adjustable stops on the tractor’s hydraulic lift lever or the Pull-Type hydraulic cylinder rod so the cutter can be consistently returned to the same cutting and transport height.

You should now be ready to transport to your cutting site at a safe ground speed. On roadways transport in such a manner that faster moving vehicles can easily see you and pass you safely. Reduce your speed when travelling over rough and hilly terrain. Avoid quick or sharp steering corrections. Take extra care to ensure that the mower doesn’t come into contact with obstacles such as trees, buildings, or fences. Use accessory lights and appropriate reflective devices to provide adequate warning to pedestrians and other vehicle operators when traveling on public roads and in the dark of night. Comply with all local, state, and federal laws.

It is important that you inspect the area where you will be cutting and clear it of safety hazards and foreign objects either before or after you arrive at the cutting site. Never assume the area is clear. Cut only in areas you are familiar with and are free of debris and unseen objects. Extremely tall grass should be cut twice to detect potential hazards. In the event you do strike an object stop the cutter and tractor immediately to inspect and make necessary repairs to the cutter before resuming operation. It really pays to inspect a new area and to develop a safe plan before cutting.

Section 3: Operating Instructions

You will need to maintain 540 RPM PTO speed and 2 to 5 mph ground speed to produce a clean cut. Make a tractor gear and range selection that will enable you to maintain these speed combinations. Generally the quality of cut is better at lower ground speeds. Dense ground cover will create the need to slow down even more. In certain conditions tractor tires will roll grass down resulting in an uneven cut when the grass fails to rebound. Should this happen you may try reversing the direction of cut and/or double cut to achieve the desired finish. Avoid very low cutting heights especially on extremely uneven terrain. Always cut downward on slopes and avoid crossing the face of steep slopes. Avoid sharp drops and cross diagonally through dips to prevent hanging up the tractor and cutter. Slow down in turns. Remember to look back often.

Now that you're prepared and well briefed you may begin cutting. Begin by doing the following:

- Reducing tractor's engine rpm.
- Make sure cutter is on the ground in cutting position and then engage PTO.
- Raise engine rpm to the appropriate 540 PTO speed and begin cutting.

Make wide turns when possible. 3-Point hitch and optional Quick Hitch models can be lifted into transport position to make tight turns and to reverse direction. Try increasing or decreasing ground speed to determine the effect on quality of cut. With a little practice you will be pleased with what your Land Pride Rotary Cutter can do.

Whether you are done mowing, need to take a break, or just need to make a few adjustments to the cutter, remember to always do the following:

- Reduce tractor's engine rpm and disengage PTO.
- Stop on level ground, set park brake, turn off engine and remove switch key.
- Stay on the tractor until the cutter blades have come to a complete dead stop.

Section 4: Maintenance & Lubrication

Maintenance

Proper servicing and adjustments are key to the long life of any implement. With careful inspection and routine maintenance, you can avoid costly downtime and repair.

Check all bolts and pins after using the unit for several hours and on a regular basis thereafter to ensure they are tight and secured. Replace worn, damaged or illegible safety labels by obtaining new labels from your Land Pride Dealer.

CAUTION

Do not alter Land Pride equipment or replace parts with other brands. Doing so can cause equipment to perform improperly and may lead to breakage that can cause bodily injury. Replace parts only with genuine Land Pride parts.

CAUTION

Buildup of debris around moving parts and gearboxes is a fire hazard. Keep rotating parts and gearboxes free from debris to avoid serious injury and property damage.

CAUTION

Improper oil level can cause bearing failure and be a fire hazard. Maintain proper gearbox oil level to avoid serious injury and property damage.

Slip-Clutch Protected Drivelines

The drive-train is protected from shock loads with a four plate slip-clutch. The slip-clutch must be capable of slippage during operation. Always do a “Clutch Run-In” operation at the beginning of each season and after long periods of inactivity to remove any oxidation that may have accumulated on the friction surfaces. Repeat “Clutch Run-In” instructions below when moisture and/or condensation seizes the inner friction plates.

WARNING

Always disengage PTO, engage parking brake, shut off tractor, remove ignition key, and wait for all moving parts to come to a complete stop before dismantling tractor to make adjustments.

Clutch Run-In

Refer to Figure 4-2:

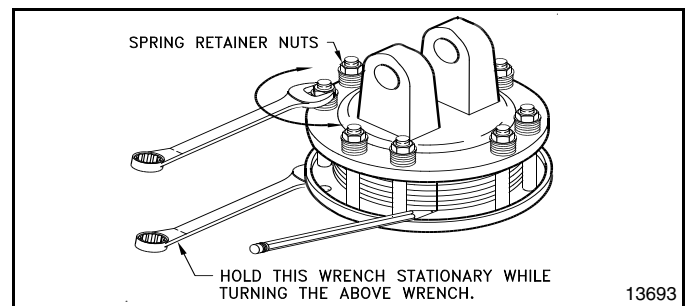

Clutch
Figure 4-2

1. Using a pencil or other marker, scribe a line across the exposed edges of the clutch plates and friction discs.
2. Carefully loosen each of the 8 spring retainer nuts by exactly 2 revolutions. It will be necessary to hold hex end of retainer bolt in order to count the exact number of revolutions.
3. Start tractor and engage PTO drive for 2-3 seconds to permit slippage of the clutch surfaces. Disengage PTO, then re-engage a second time for 2-3 seconds. Disengage PTO, shut off tractor, and remove key. Wait for all components to stop before dismantling from tractor.
4. Inspect clutch and ensure that the scribed markings made on the clutch plates have changed position. Slippage has not occurred if any two marks on the friction disc and plate are still aligned. A clutch that has not slipped must be disassembled to separate the friction disc plates. See “Clutch Assembly and Disassembly” on page 30.
5. Tighten each of the 8 spring retainer nuts on the clutch housing exactly 2 revolutions to restore the clutch to the original setting pressure.
6. The clutch should be checked during the first hour of cutting and periodically each week. An additional set of scribe marks can be added to check for slippage. See Figure 4-4 on page 30 to adjust spring length.

Section 4: Maintenance & Lubrication

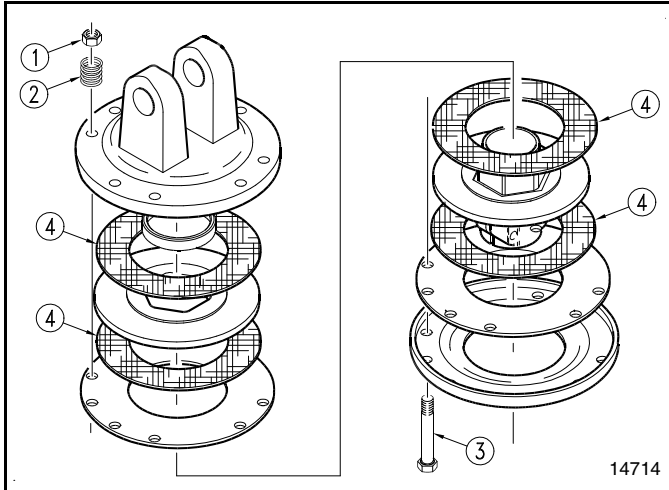

Clutch Disassembly
Figure 4-3

Clutch Assembly and Disassembly

Disassembly

Refer to Figure 4-3:

IMPORTANT: Refer to Figure 4-4. Be Sure to measure and record length (“A”) of each clutch spring before disassembling clutch.

See “IMPORTANT NOTE” above before disassembling clutch. After measuring and recording each spring length, remove spring retainer nuts (#1), springs (#2) and bolts (#3). Each friction disc (#4) must then be separated from the metal surface adjacent to it. Refer to the Parts Manual for a detailed parts breakdown.

Inspection

Inspect all parts for excessive wear and condition. Clean all parts that do not require replacement. The original friction disc thickness is 1/8" (3.2mm) and should be replaced if thickness falls below 3/64" (1.1mm). If clutches have been slipped to the point of “smoking”, the friction discs may be damaged and should be replaced. Heat build-up may also affect the yoke joints.

Assembly

Refer to Figure 4-4:

Reassemble each friction disc (#4) next to the metal plate it was separated from. Install bolts (#3) through end plates and intermediate plates as shown. Place springs (#2) over bolts (#3) and secure with nuts (#1).

Refer to Figure 4-4:

Progressively tighten each spring retainer bolt until correct spring height “A” dimension is obtained.

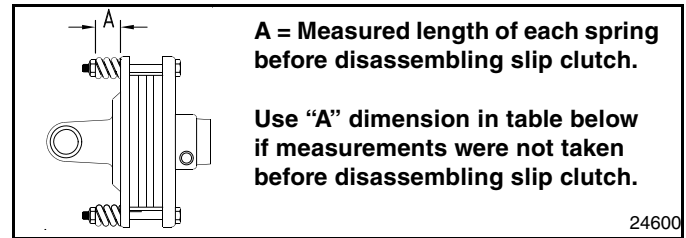

24600

Model No.	Driveline No.	PTO Speed	Ca t No	A (inches) Spring Height
RCF2784	826-152C 826-673C	540	4	1.11" to 1.12" 1.319"

Clutch Adjustment
Figure 4-4

Cutter Blade Maintenance

DANGER

Always disconnect driveline from tractor PTO shaft before servicing underside of cutter. If tractor is started with PTO engaged, the cutter can cause bodily injury or death.

DANGER

Always secure cutter deck in the up position with solid supports before servicing underside of cutter. Never work under equipment supported by hydraulics. Hydraulics can drop equipment if controls are actuated or if hydraulic lines burst. Either situation can drop the cutter instantly even when power to the hydraulics is shut off.

WARNING

Keep blade bolt access hole covered at all times except when servicing cutter blades. Make sure driveline is disconnected from the tractor before servicing cutter blades.

WARNING

Do not operate cutter with blades that are out-of-balance, bent, excessively worn, excessively nicked, or with blade bolts that are excessively worn. Such blades can break loose from the cutter at high speeds causing serious injury or death.

WARNING

Do not attempt to straighten a bent blade or weld on a blade. Do not attempt to modify a blade such as hard surfacing, heat treating, cold treating, or by any other method. Always replace blades with a new Land Pride blade to assure safety.

Section 4: Maintenance & Lubrication

IMPORTANT: Replace cutting blades in pairs with genuine Land Pride blades only. Replacing single blades can result in an out-of-balance condition that will contribute to premature bearing wear/breakage and/or structural cracks in gearbox and/or deck.

Always inspect cutting blades before each use. Make certain they are properly installed and are in good working condition. Replace any blade that is damaged, worn, bent, or excessively nicked. Small nicks can be ground out.

Remove blades and sharpen or replace as follows:

1. Place tractor gear selector in park and set brakes, shut engine off and remove ignition key.
2. Disconnect main driveline from tractor PTO and secure cutter deck in the up position with solid supports before servicing underside of cutter.
3. Inspect cutting blades. Make certain they are properly installed and are in good working condition. Replace any blade that is damaged, worn, bent, or excessively nicked. Small nicks can be ground out.

Refer to Figure 4-1:

4. To remove blades from the cutter, remove access cover (#6).
5. Rotate blade bolt (#1) until aligned with access hole (A).
6. Unscrew locknut (#3) to remove cutting blade (#6). Blade bolt (#1) is keyed and will not turn freely.
7. Repeat steps 5 & 6 for the other blade.
8. Both blades should be sharpened at the same angle as the original cutting edge and must be replaced or re-ground at the same time to maintain proper balance in the cutting unit. The following precautions should be taken when sharpening blades:
 - a. Do not remove more material than necessary.
 - b. Do not heat and pound out a cutting edge.
 - c. Do not grind blades to a razor edge. Leave a blunt cutting edge approximately 1/16" thick.
 - d. Always grind cutting edge so end of blade remains square to cutting edge and not rounded.
 - e. Do not sharpen back side of blade.
 - f. Both blades should weigh the same with not more than 1 1/2 oz. difference. Unbalanced blades will cause excessive vibration which can damage gearbox bearings and create structural cracks.
9. Carefully check cutting edges of blades in relation to blade carrier rotation to ensure correct blade placement. Blade rotation is counterclockwise with cutting edge leading. Airfoil (lift) must be oriented towards the top of the deck.

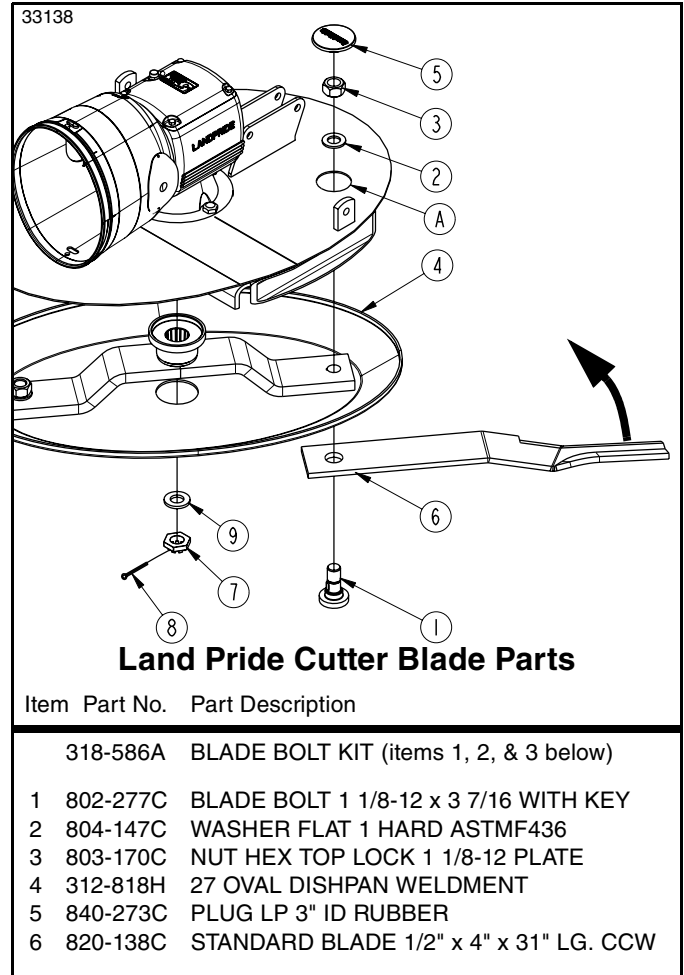

**Cutter Blade Assembly (Counterclockwise Rotation)
Figure 4-1**

IMPORTANT: Examine blade bolts (#1) and flat washers (#2) for excessive wear and replace if worn.

IMPORTANT: Locknuts can loose their ability to lock properly once removed. Always use a new locknut when installing blades.

10. Insert blade bolt (#1) through blade (#6), dish pan (#4), and flat washer (#2). Secure blade with a **new locknut (#3)** and torque to 450 ft-lb.
11. Repeat step 10 for the other blade.
12. Replace access cover (#5).
13. If replacing dishpan (#4), nut (#7) on gearbox output shaft should be torqued to 450 ft-lbs. minimum and cotter pin (#8) installed with both legs bent opposite directions around the nut.

Skid Shoe Maintenance

Refer to Figure 4-5:

326-120A Skid Shoe Kit
(Includes 2 skid shoes & mounting hardware)

! WARNING

Excessive wear on skid shoes can damage side panels, cause inadequate operation of cutter, and create a safety hazard. Always replace skid shoes at the first sign of wearing thin.

There are skid shoes mounted on the cutter sides. Check both skid shoes for wear and replace if necessary. Order only genuine Land Pride parts from your local Land Pride dealer.

1. Remove 3/8" hex whiz nuts (#3), 3/8" plow bolts (#2), and skid shoe (#1) as shown.
2. Plow bolts should be checked for wear and replaced when worn.
3. Attach new skid shoe (#1) to cutter with existing 3/8" plow bolts (#2), and secure with 3/8" hex whiz nuts. Tighten to the correct torque.
4. Repeat on opposite side.

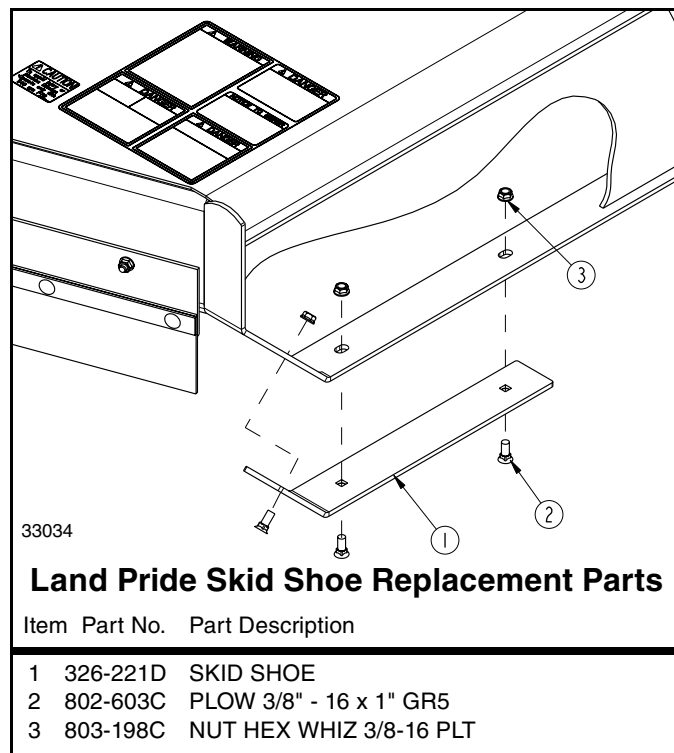

**Skid Shoe Replacement
Figure 4-5**

Section 4: Maintenance & Lubrication

Long Term Storage

Clean, inspect, service, and make necessary repairs to the cutter when parking it for long periods and when parking it at the end of a working season. This will help ensure the cutter is ready for field use the next time you hook-up to it.

 **DANGER**

Always disconnect driveline from tractor PTO shaft before servicing drive train components and cutter blades. The PTO can be engaged if tractor is started causing bodily injury or death.

 **DANGER**

Always secure cutter deck in the up position with solid supports before servicing underside of cutter. Never work under equipment supported by hydraulics. Hydraulics can drop equipment if controls are actuated or if hydraulic lines burst. Either situation can drop the cutter instantly even when power to the hydraulics is shut off.

 **CAUTION**

Always store cutter with 3-point hitch pivoted back as far as possible. The floating 3-point hitch when not hooked to a tractor can fall backwards unexpectedly causing bodily injury.

1. Clean off any dirt and grease that may have accumulated on the cutter and moving parts. Scrape off compacted dirt from the bottom of deck and then wash surface thoroughly with a garden hose. A coating of oil may also be applied to the lower deck area to minimize oxidation.
2. Check blades and blade bolts for wear and replace if necessary. See “**Cutter Blade Maintenance**” on page 30.
3. Inspect for loose, damaged or worn parts and adjust or replace as needed.
4. Repaint parts where paint is worn or scratched to prevent rust. Ask your Land Pride dealer for aerosol touch-up paint. They are also available in touch-up bottles with brush, quarts, and gallon sizes by adding TU, QT, or GL to the end of the aerosol part number.

Land Pride Aerosol Touch-up Paint	
Part No.	Part Description
821-011C	PAINT LP BEIGE AEROSOL SPRAY CAN
821-002C	PAINT LP BLACK AEROSOL SPRAY CAN
821-054C	PAINT MEDIUM RED AEROSOL SPRAY CAN
821-058C	PAINT GREEN AEROSOL SPRAY CAN
821-066C	PAINT ORANGE AEROSOL SPRAY CAN

5. Replace all damaged or missing decals.
6. Lubricate as noted in “**Lubrication Points**” starting on page 34.

7. Store cutter on a level surface in a clean, dry place. Inside storage will reduce maintenance and make for a longer cutter life.
8. Follow all unhooking instructions on page 27 when disconnecting tractor from cutter.

Ordering Replacement Parts

Land Pride offers equipment in factory standard beige color with black highlights. Equipment in special colors may be purchased in Green, Red or Orange. Because of the variety of colors available, special attention must be given to the part number to prevent ordering the wrong replacement part. A suffix number corresponding to one of the colors below must be added at the end of Land Pride’s part number when ordering a replacement part with that color. Parts ordered without a suffix number will be supplied in factory standard colors.

- | | |
|-----------------------------------|----------------------------------|
| 81 Green | 83 Red |
| 82 Orange | 85 Black |

For example, if you are ordering a replacement part with part number 555-555C and the existing part is red, then add the suffix 83 to the end of the number to make the part number read 555-555C83.

Lubrication Points

Lubrication Legend	Multi-purpose spray lube	Multi-purpose grease lube	Multi-purpose oil lube	50 Hrs Intervals in hours at which lubrication is required

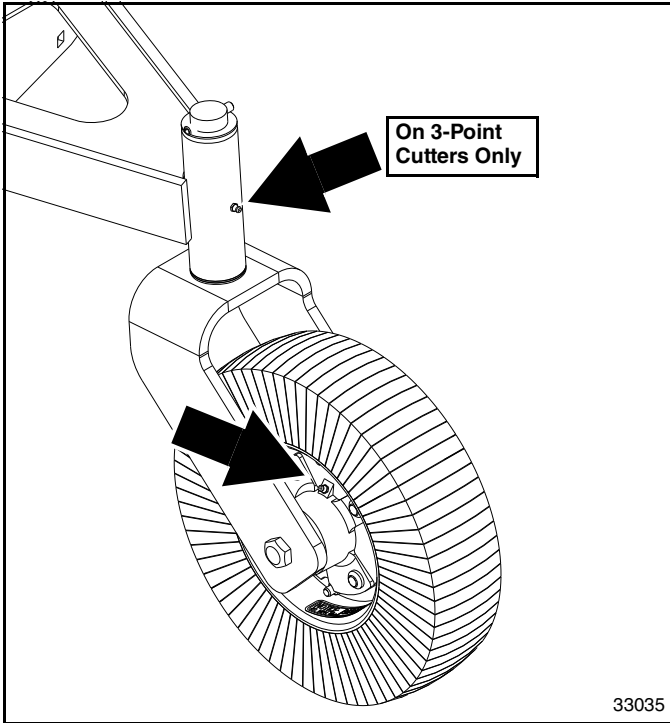

	24 Hours
--	----------

Gauge Wheel Spindle Tube (3-Point Cutters)

Type of Lubrication: Multi-purpose Grease

Quantity = 6 pumps

Gauge Wheel Hub

	8 Hours
--	---------

Type of Lubrication: Multi-purpose Grease

Quantity = 2 pumps

Gearbox

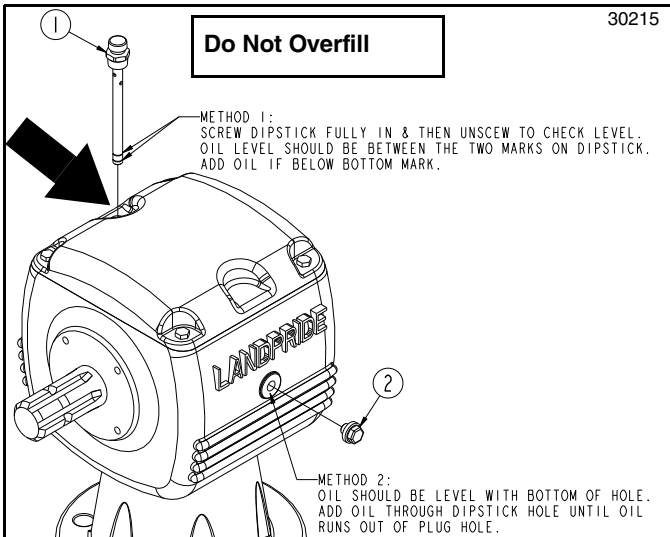

	8 Hours
--	---------

NOTE: Do not overfill! Cutter should be level when checking oil. Oil expands when hot, therefore, always check oil level when cold.

Method 1: Unscrew top vented dipstick (#1). Wipe oil from dipstick and screw dipstick in without tightening. Unscrew dipstick and check oil on dipstick. If below bottom level mark, add recommended gear lube through dipstick hole until oil reaches top mark on dipstick. Reinstall vented dipstick and tighten.

Method 2: Remove side oil plug (#2). If oil is below bottom of plug hole, add recommended gear lube through top dipstick hole until oil flows out of side plug hole. Reinstall and tighten side oil plug (#2) and vented dipstick (#1).

Type of Lubrication: 80-90W EP Gear Lube

Quantity = Fill until oil reaches top mark on dipstick or begins to flow out side plug hole in gearbox.

IMPORTANT: Your cutter is shipped with a vented dipstick packaged in the Operator's Manual bag and should have been installed in the gearbox by your Land Pride dealer. Please see your Land Pride dealer if vented dipstick was not included.

NOTE: Use a suction or siphon pump to drain gearboxes of oil when there is not an oil drain plug.

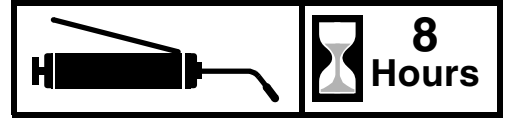
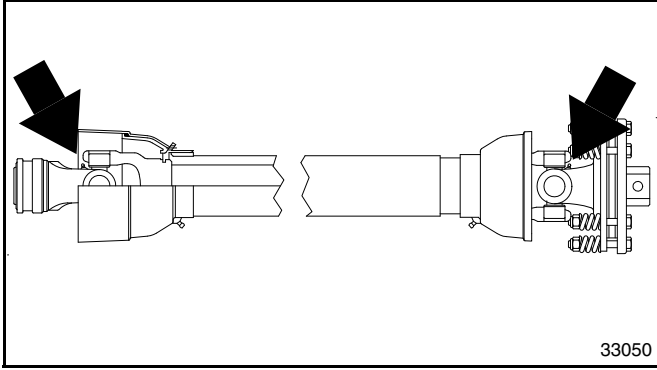

Driveline U-Joints

Type of Lubrication: Multi-purpose Grease
Quantity = 6 pumps

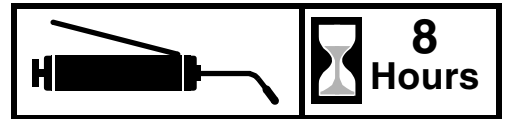
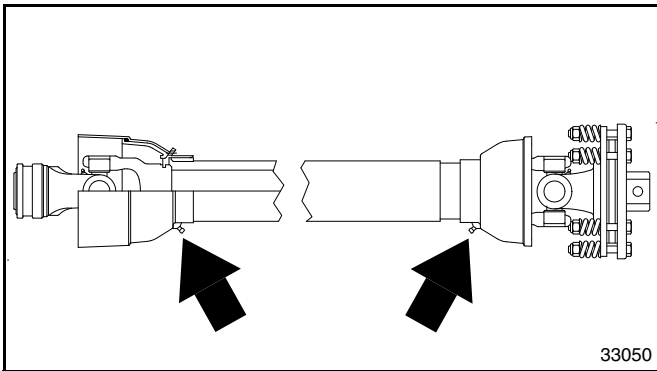

Driveline Shield Bearings

Type of Lubrication: Multi-purpose Grease
Quantity = 6 pumps

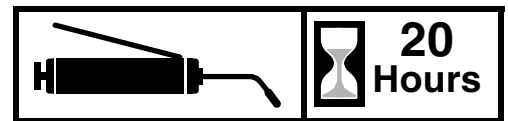
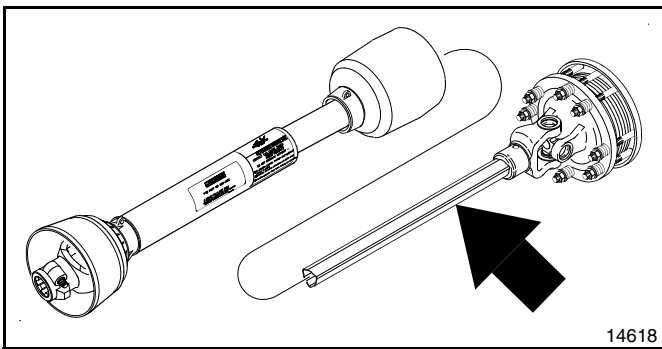

Driveline Profiles

Type of Lubrication: Multi-purpose Grease
Quantity = Clean & coat inner tube of driveline with a light film of grease and then reassemble.

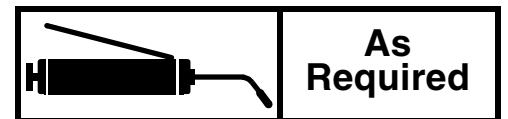
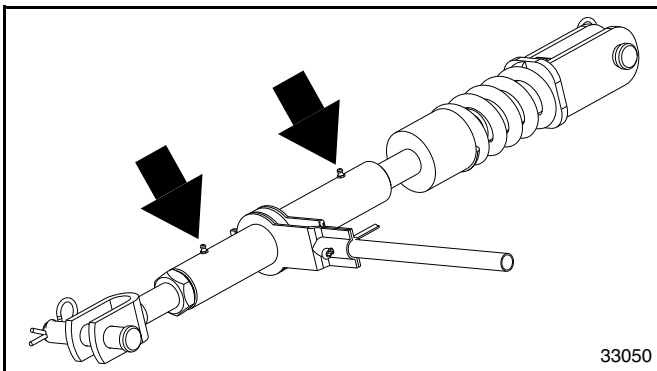

Ratchet Jack (Optional)

Type of Lubrication: Multi-purpose Grease
Quantity = Until grease purges from threads.



RCF2784 Model

Specifications & Capacities		
Machine Weight		
3-Point Single Tailwheel		1,354 lbs. with front & rear chain guards
3-Point Dual Tailwheel		1,427 lbs. with front & rear chain guards
Pull-Type Dual Tailwheel		1,632 lbs. with front & rear chain guards and hydraulic type adjustment
Hitch		Category II & III with floating top linkage, Quick Hitch adaptable
Cutting Width		84"
Overall Width		89"
Overall Length		
3-Point Single Tailwheel		132 1/2"
3-Point Dual Tailwheel		130 3/8"
Pull-Type Dual Tailwheel		159 1/4"
Deck Height (Bottom of Deck to Bottom of Skid Shoe)		10 1/8"
Cutting Height		1 1/2" to 12"
Cutting Capacity		3" Diameter
Recommended Tractor PTO HP		60-130 HP
PTO Speed		540 RPM
Gearbox Ratio		1:1.21
Gearbox Construction		Speed-up beveled gears, cast iron housing, 1 3/8"-6 spline input shaft and 2" output shaft
Gearbox Oil Capacity & Type		6.5 Pints of EP 80-90W oil
Deck Construction		All welded deck
Deck Material Thickness		10 Gauge (.134")
Side Skirt Material Thickness		1/4"
Skid Shoes		1/4" x 2 1/2" x 18 7/16" Long bolt-on replaceable skid shoes
Stump Jumper		3/16" x 24" x 38" Oval Pan with 1" thick blade holder bar
Blades (2)		1/2" x 4" x 31" Heat treated alloy steel free-swinging high lift
Blade Bolts		Keyed with harden flat washers & lock nuts.
Blade Tip Speed		14,369 FPM
Driveline		ASAE Category 4
Driveline Protection		4 Plate slip clutch
Tailwheel Mount		Welded A-arm and caster fork with 360 degree swivel
Tailwheel		4" x 8" x 15" Laminated tire with cast iron hub
Front Guard	Optional	Rubber Belting
	Optional	Single Chain Guard
Rear Guard	Optional	Single Chain Guard

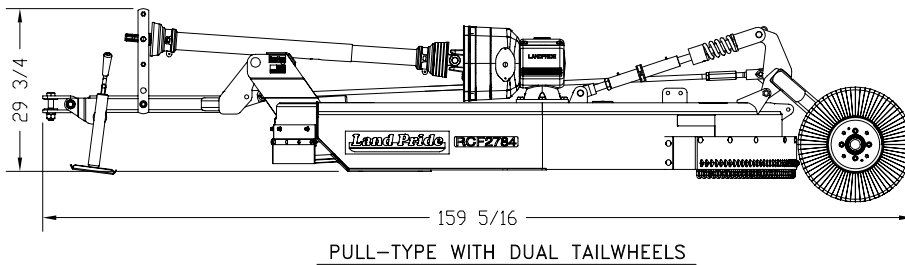
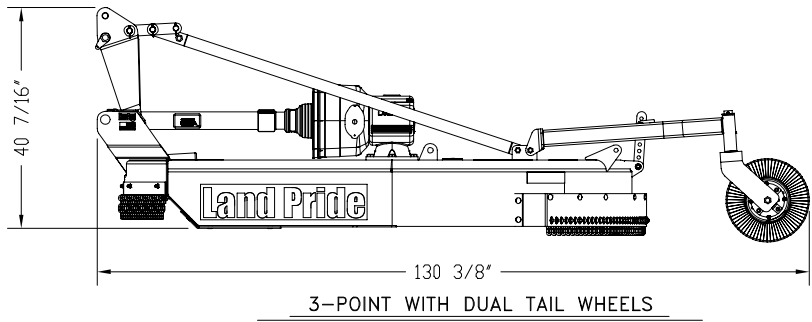
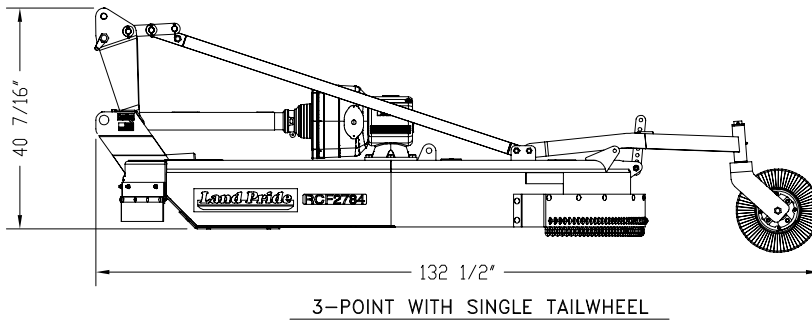
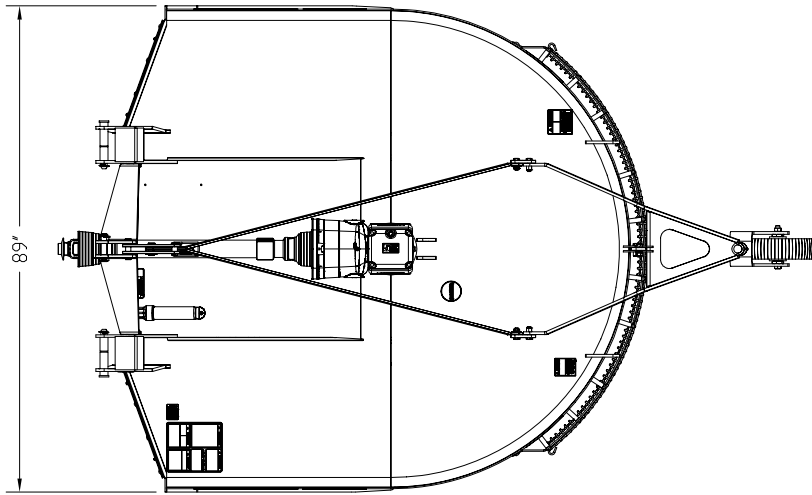

33037



RCF2784 Model

Features	Benefits
Surpassed rugged industry standards	All Land Pride Cutters have been designed and tested and meet rigorous voluntary testing procedures specified by ANSI.
5 Year gearbox warranty	Shows our confidence in the gearbox integrity.
Gearbox Seal Protection	Gearbox bottom seal protection for longer bearing life.
Cat. 4 driveline with 4-plate slip-clutch	Slip-clutch driveline offers convenience for continual work.
Dual position clevis type 3-Point floating top link	Permits deck to follow the terrain for an even cut.
Lower clevis type 3-Point hitch	Allows for ease of hook-up to tractor. Also adds additional strength allowing for an even pull from the tractor's lower arms, vs. pulling on a single pin design.
Heavy 10 gauge deck & 1/4" side skirt construction	Can withstand more abuse than lighter gauge decks.
Box tubing deck supports	Makes for a stronger rigid deck.
Fully welded deck	Adds additional strength.
Extended cutter front	For increased material flow and added protection.
Round back design	Helps discharge grass better than enclosed or partially enclosed cutters.
10 1/8" Deck Height	Allows cutter to handle heavy cutting conditions.
1 1/2" to 12" Cutting height	Provides for a wide range of cutting conditions.
1/4" x 2 1/2" x 18 7/16" Long skid shoes	Provides sidewall reinforcement and protection to bottom of sidewall.
1/2" x 4" Heat-treated free swinging blades	Free swinging protects from obstructions. Heat-treated offers longer life.
Splined blade bar hub	Allows for tight positive fit of stump jumper and blade bar to gearbox output shaft.
3/16" x 24" x 38" Oval stump jumper	Standard Oval stump jumper slides over stumps, rocks and debris.
High blade tip speed	Ensures clean cut.
15" Laminated tailwheel	Laminated material is long lasting in rough conditions. Can't go flat.
1 1/2" Heavy-duty spindle on tailwheel	Tailwheels take a beating, spindle gives the strength to protect tailwheel assembly.
Optional Front Guarding	Protect against flying debris. Customer can choose to include single chain or rubber guarding.
Single Chain Rear Guarding	Protect against flying debris.



Troubleshooting Chart

Problem	Cause	Solution
Oil seal leaking	Gearbox overfilled	Drain to side plug hole
	Seals damaged	Replace seals
	Grass or wire wrapped on shaft in seal area	Check seal areas daily
Driveline yoke or cross failing	Shock load	Avoid hitting solid objects
	Needs lubrication	Lubricate every 8 hours
Driveline clutch is slipping	Scalping the ground	Raise cutting height
	Cutting too fast	Reduce travel speed
	PTO being engaged too fast at high engine RPM	Slowly engage PTO at low engine RPM
	Cutting over solid objects	Avoid solid objects
Bent Driveline (NOTE: driveline should be repaired or replaced if bent)	Contacting frame	Reduce lift height in transport position
	Contacting drawbar	Reposition drawbar
	Bottoming out	Shorten driveline
	Binding up	Not lubricating enough
Driveline telescoping tube failing	Shock load	Avoid hitting solid objects
Driveline telescoping tube wearing	Needs lubrication	Lubricate every 20 hours
Blades Lock-up	Tractor has instant on PTO	Engage PTO at low RPMs and then slowly increase engine speed to full PTO speed. See Blade Engagement on page 26.
	Tractor has Instant off PTO	Decrease engine speed slowly to an idle and then disengage PTO. See Blade Disengagement on page 26.
Blades wearing excessively	Cutting on sandy ground	Raise cutting height
	Contacting ground frequently	Raise cutting height
Blades breaking	Hitting solid objects	Avoid hitting solid objects
Blades coming loose	Blades not tightened properly	Tighten blade hardware (refer to "Cutter Blade Maintenance" on page 30)
	Improper deck attitude	Lower front of deck, see page 21
Blade carrier becomes loose	Running loose in the past	Replace gearbox output shaft and blade carrier
	Blade carrier hardware not tight enough	Tighten to specified torque
Blade bolt holes worn	Blade hardware running loose	Replace blades and blade bolts if worn
Blade carrier bent	Hitting solid objects	Avoid hitting solid objects and replace blade carrier
Excessive side skid wear	Cutting height not level	Adjust cutter height
	Soil abrasive	Adjust cutter height
	Cutting too low	Adjust cutter height
Tailwheel support failing	Lowering too fast	Adjust rate of drop
	Hitting objects when turning	Reduce speed on turns
Excessive vibration	Driveline bent	Replace driveline
	Blades loose	Tighten blade bolts
	Blade carrier bent	Replace blade carrier
	Blade broken	Replace blade
	Blade will not swing	Remove and inspect blade
	Blades have unequal weight	Replace both blades



Torque Values Chart for Common Bolt Sizes													
Bolt Size (inches)	Bolt Head Identification						Bolt Size (Metric)	Bolt Head Identification					
	Grade 2		Grade 5		Grade 8			Class 5.8		Class 8.8		Class 10.9	
in-tpi ¹	N · m ²	ft-lb ³	N · m	ft-lb	N · m	ft-lb	mm x pitch ⁴	N · m	ft-lb	N · m	ft-lb	N · m	ft-lb
1/4" - 20	7.4	5.6	11	8	16	12	M 5 X 0.8	4	3	6	5	9	7
1/4" - 28	8.5	6	13	10	18	14	M 6 X 1	7	5	11	8	15	11
5/16" - 18	15	11	24	17	33	25	M 8 X 1.25	17	12	26	19	36	27
5/16" - 24	17	13	26	19	37	27	M 8 X 1	18	13	28	21	39	29
3/8" - 16	27	20	42	31	59	44	M10 X 1.5	33	24	52	39	72	53
3/8" - 24	31	22	47	35	67	49	M10 X 0.75	39	29	61	45	85	62
7/16" - 14	43	32	67	49	95	70	M12 X 1.75	58	42	91	67	125	93
7/16" - 20	49	36	75	55	105	78	M12 X 1.5	60	44	95	70	130	97
1/2" - 13	66	49	105	76	145	105	M12 X 1	90	66	105	77	145	105
1/2" - 20	75	55	115	85	165	120	M14 X 2	92	68	145	105	200	150
9/16" - 12	95	70	150	110	210	155	M14 X 1.5	99	73	155	115	215	160
9/16" - 18	105	79	165	120	235	170	M16 X 2	145	105	225	165	315	230
5/8" - 11	130	97	205	150	285	210	M16 X 1.5	155	115	240	180	335	245
5/8" - 18	150	110	230	170	325	240	M18 X 2.5	195	145	310	230	405	300
3/4" - 10	235	170	360	265	510	375	M18 X 1.5	220	165	350	260	485	355
3/4" - 16	260	190	405	295	570	420	M20 X 2.5	280	205	440	325	610	450
7/8" - 9	225	165	585	430	820	605	M20 X 1.5	310	230	650	480	900	665
7/8" - 14	250	185	640	475	905	670	M24 X 3	480	355	760	560	1050	780
1" - 8	340	250	875	645	1230	910	M24 X 2	525	390	830	610	1150	845
1" - 12	370	275	955	705	1350	995	M30 X 3.5	960	705	1510	1120	2100	1550
1-1/8" - 7	480	355	1080	795	1750	1290	M30 X 2	1060	785	1680	1240	2320	1710
1-1/8" - 12	540	395	1210	890	1960	1440	M36 X 3.5	1730	1270	2650	1950	3660	2700
1-1/4" - 7	680	500	1520	1120	2460	1820	M36 X 2	1880	1380	2960	2190	4100	3220
1-1/4" - 12	750	555	1680	1240	2730	2010	¹ in-tpi = nominal thread diameter in inches-threads per inch ² N · m = newton-meters ³ ft-lb= foot pounds ⁴ mm x pitch = nominal thread diameter in millimeters x thread pitch						
1-3/8" - 6	890	655	1990	1470	3230	2380							
1-3/8" - 12	1010	745	2270	1670	3680	2710							
1-1/2" - 6	1180	870	2640	1950	4290	3160							
1-1/2" - 12	1330	980	2970	2190	4820	3560							
Torque tolerance + 0%, -15% of torquing values. Unless otherwise specified use torque values listed above.													
Additional Torque Values													
Blade Bolt Lock Nut							450 ft-lbs						
Blade Carrier Hub Nut							450 ft-lbs Minimum						

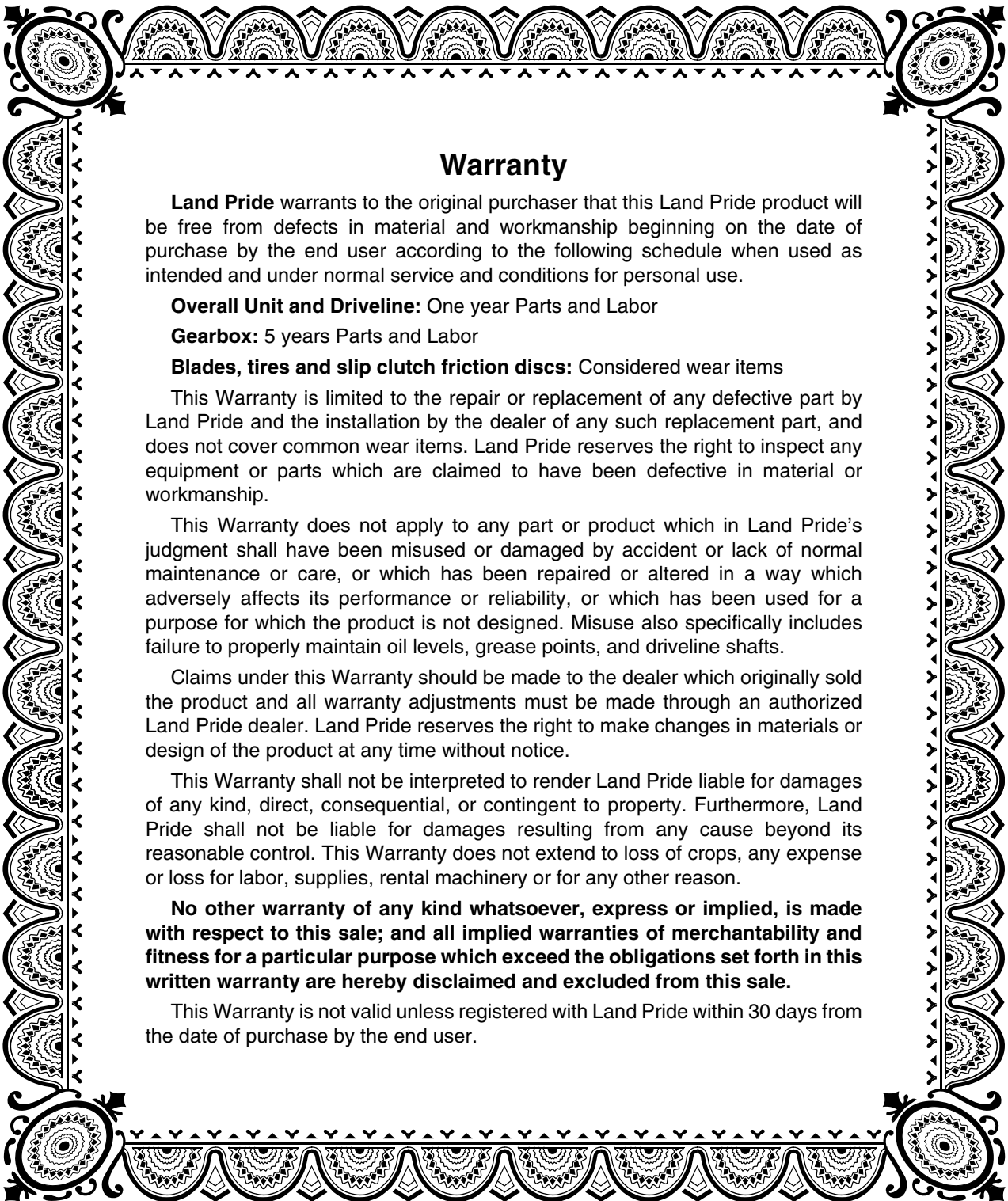

Warranty

Land Pride warrants to the original purchaser that this Land Pride product will be free from defects in material and workmanship beginning on the date of purchase by the end user according to the following schedule when used as intended and under normal service and conditions for personal use.

Overall Unit and Driveline: One year Parts and Labor

Gearbox: 5 years Parts and Labor

Blades, tires and slip clutch friction discs: Considered wear items

This Warranty is limited to the repair or replacement of any defective part by Land Pride and the installation by the dealer of any such replacement part, and does not cover common wear items. Land Pride reserves the right to inspect any equipment or parts which are claimed to have been defective in material or workmanship.

This Warranty does not apply to any part or product which in Land Pride's judgment shall have been misused or damaged by accident or lack of normal maintenance or care, or which has been repaired or altered in a way which adversely affects its performance or reliability, or which has been used for a purpose for which the product is not designed. Misuse also specifically includes failure to properly maintain oil levels, grease points, and driveline shafts.

Claims under this Warranty should be made to the dealer which originally sold the product and all warranty adjustments must be made through an authorized Land Pride dealer. Land Pride reserves the right to make changes in materials or design of the product at any time without notice.

This Warranty shall not be interpreted to render Land Pride liable for damages of any kind, direct, consequential, or contingent to property. Furthermore, Land Pride shall not be liable for damages resulting from any cause beyond its reasonable control. This Warranty does not extend to loss of crops, any expense or loss for labor, supplies, rental machinery or for any other reason.

No other warranty of any kind whatsoever, express or implied, is made with respect to this sale; and all implied warranties of merchantability and fitness for a particular purpose which exceed the obligations set forth in this written warranty are hereby disclaimed and excluded from this sale.

This Warranty is not valid unless registered with Land Pride within 30 days from the date of purchase by the end user.

IMPORTANT: The Online Warranty Registration should be completed by the dealer at the time of purchase. This information is necessary to provide you with quality customer service.

Model Number _____

Serial Number _____



Corporate Office: P.O. Box 5060
Salina, Kansas 67402-5060 USA
www.landpride.com
